



BC107DE2/BC96DE2-AU series

User Manual for Industrial and Commercial Battery Cabinet



Overview

This manual introduces the main characteristics, performance indicators, system principles, appearance, and structure of the BC107DE2/BC96DE2-AU series industrial and commercial battery cabinet. It also provides instructions for installation, use, operation,

and maintenance management.





Audience

This document is intended primarily for the following engineers:

- Sales Engineer
- Technical Support Engineer
- System Engineer
- Hardware Installation Engineer
- Commissioning and Testing Engineer
- Maintenance Engineer

Symbol conventions

The following symbols may be indicated herein, with their meanings shown as follows.

| Symbol | Description |
|--|---|
|  DANGER | Indicates a hazard that, if not avoided, will result in a high risk of death or serious injury. |
|  WARNING | Indicates a medium-risk hazard that, if not avoided, could lead to death or serious injury. |
|  CAUTION | Indicates a low-risk hazard that, if not avoided, may result in minor or moderate injury. |
| NOTICE | It transmits equipment or environmental safety warning information. Not doing so may lead to equipment damage, data loss, degraded equipment performance, or other unpredictable outcomes. The "Instructions" do not pertain to personal injury. |
|  Description | Supplementary explanation of key information in the text. "Note" is not a safety warning message and does not involve personal, equipment, or environmental damage. |

Record of Revision

| Version | Date of revision | Revised content | Internal document number |
|---------|------------------|-------------------------------|--------------------------|
| A | 2025/05/12 | First version | / |
| B | 2025/07/1 | Increase Fire Protection Unit | / |
| | | | |
| | | | |
| | | | |
| | | | |

| | | | |
|--|--|--|--|
| | | | |
| | | | |
| | | | |
| | | | |

Table of Contents

| | | |
|---------|--|----|
| 1 | General safety precautions..... | 1 |
| 1.1 | General safety | 1 |
| 1.2 | Requirements for personnel..... | 4 |
| 1.3 | Electrical safety | 4 |
| 1.4 | Requirements for installation environment | 6 |
| 1.5 | Safety of machinery..... | 7 |
| 1.6 | Battery safety..... | 9 |
| 1.7 | Other..... | 10 |
| 2 | Overview..... | 11 |
| 2.1 | Battery system parameters | 11 |
| 2.1.1 | Cell parameters | 11 |
| 2.1.2 | Battery module parameters..... | 11 |
| 2.1.3 | Parameters of battery cabinet | 12 |
| 2.1.4 | High voltage box interface..... | 13 |
| 2.1.5 | Switch interface (Optional)..... | 14 |
| 2.1.6 | MBMU interface | 15 |
| 2.1.7 | Charge and discharge curve..... | 16 |
| 2.2 | Product introduction | 17 |
| 2.2.1 | Product appearance..... | 18 |
| 2.2.2 | Product structure | 20 |
| 2.2.3 | BC107DE2 Electrical Connection Diagram | 26 |
| 2.2.4 | Product model and naming rules | 27 |
| 3 | Installation | 29 |
| 3.1 | Site planning..... | 29 |
| 3.1.1 | Dimension of battery cabinet | 29 |
| 3.1.2 | Precautions for installation | 29 |
| 3.1.3 | Space reservation..... | 30 |
| 3.2 | Preparation of tools and instruments..... | 31 |
| 3.3 | Remove the packaging | 33 |
| 3.4 | Single cabinet installation | 33 |
| 3.4.1 | Installation environment..... | 33 |
| 3.4.2 | Installation of the cabinet..... | 33 |
| 3.4.2.3 | Fixed installation..... | 35 |
| 3.4.3 | Installation instructions for cables between battery modules | 37 |
| 3.5 | Electrical connections | 39 |
| 3.5.1 | AC input connection | 40 |
| 3.6 | Description of communication wiring | 43 |
| 3.7 | Install Ground cable for the battery cabinet..... | 45 |
| 3.8 | Installing DC Cables between PCS and ESS Cabinet..... | 47 |
| 3.9 | Installing Communication Cables between PCS and ESS Cabinet..... | 47 |
| 3.10 | Installing an awning (Optional) | 48 |
| 4 | Operation instructions | 49 |
| 4.1 | Inspection after installation..... | 49 |
| 4.2 | Inspection of operating environment..... | 50 |
| 4.3 | Power-on operation | 50 |
| 4.3.1 | Prerequisite | 50 |
| 4.3.2 | Operation steps | 51 |
| 4.4 | Power-off operation | 57 |
| 4.4.1 | Power-off steps | 57 |
| 4.4.2 | Emergency power-off..... | 59 |
| 4.5 | Commissioning of battery cabinet..... | 60 |
| 4.6 | SOC calibration operation | 60 |

| | |
|---|----|
| 5 Routine maintenance..... | 61 |
| 5.1 Maintenance | 61 |
| 5.2 Fire Protection Unit..... | 73 |
| 6 Cabinet EMS Basic Setting | 74 |
| 6.1 Time and Time Zone Setting (if Applicable) | 74 |
| 6.2 Grid Code Setting | 74 |
| 6.3 Check software firmware version | 76 |
| 6.4 Over/under voltage and frequency Setting | 76 |
| 6.5 Reverse Power Protection/Demand control settings..... | 79 |
| 6.6 PCS total power settings | 80 |
| 6.7 Operation Mode Setting | 82 |
| 7 Cloud Platform Connection..... | 85 |
| 7.1 Network Wiring and Settings..... | 85 |
| 7.2 Connecting the Collector to the KSTAR Sync Platform | 88 |
| 8 List of accessories | 90 |
| 9 Terminology..... | 92 |

1 General safety precautions

1.1 General safety

Statement

When installing, operating, and maintaining the equipment, please read this manual first and follow all safety precautions identified both on the equipment and in the manual.

The "CAUTION," "WARNING," and "DANGER" labels in this manual do not represent all safety precautions that should be observed; they only serve as a supplement to the complete set of safety precautions. Shenzhen KSTAR New Energy Co., Ltd. does not assume responsibility for any violations of general safety operation requirements or safety standards in the design, production, and use of equipment. This equipment must be used in an environment that complies with the design specifications; otherwise, it may lead to equipment failure. Any resulting functional abnormalities, component damage, personal safety accidents, or property losses are not covered by the equipment's quality assurance.

The equipment must be installed, operated, and maintained in compliance with local laws, regulations, and codes. This manual's safety precautions are meant to supplement local laws, regulations, and codes.

In any of the following circumstances, Shenzhen KSTAR New Energy Co., Ltd. shall not be liable.

- The product is not operated according to the conditions of use described in this manual.
- Installation and usage environment exceed the requirements of relevant international or national standards.
- Disassembling or modifying the product or software code without authorization.
- Failure to follow the operating instructions and safety warnings in the product documentation.
- Damage to equipment due to abnormal natural environments (force majeure events like earthquakes, fires, storms, etc.).
- Transport damage caused by the customer's own transport.
- Damage is caused by storage conditions that do not meet the requirements of the product documentation.

General requirements

- Installing, using, and operating outdoor equipment and cables—including handling equipment, operating equipment and cables, plugging and unplugging signal interfaces connected to the outdoors, high-altitude operations, and outdoor installation—is strictly prohibited during severe weather conditions such as lightning, rain, snow, and level 6 gales.
- Wearing watches, bracelets, rings, necklaces, and other conductive objects is strictly prohibited during installation, operation, and maintenance to prevent electric shock and burns.
- During installation, operation, and maintenance, special protective equipment must be used, including insulating gloves, goggles, safety clothing, helmets, and shoes, as illustrated in the figure below.

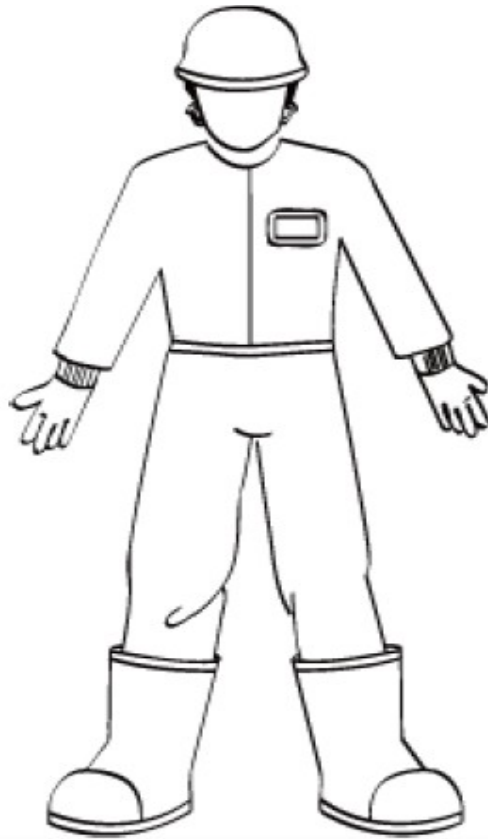

- Installation, operation, and maintenance must follow the step-by-step order outlined in the instruction manual.
- Before touching any conductive surface or terminal, measure the voltage at the contact point to confirm there is no risk of electric shock.
- After installing the equipment, remove empty packaging materials like cartons, foam, plastic, and cable ties from the equipment area.
- If a fire occurs, evacuate the building or equipment area, and then press the fire alarm or call the fire department. You should never re-enter a burning building under any circumstances.
- Do not disable protective devices or ignore warnings, cautions, and precautions in manuals and on the equipment. Promptly replace danger signs that have become unclear due to long-term use.
- Except for the personnel operating the equipment, no one else is allowed to approach it.
- The tools used need to be insulated, or insulated tools should be used, as shown in the figure below.

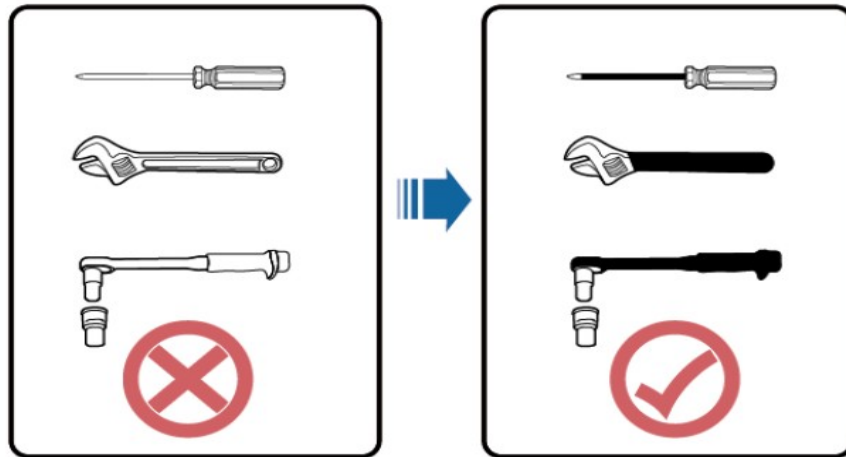

- All wiring holes need to be sealed. Use fire-proof mud to seal the wiring holes where wiring has been routed, and use the covers provided with the cabinet to seal the wiring holes that are not routed. The correct fire-proof mud sealing construction standards are shown in the figure below.

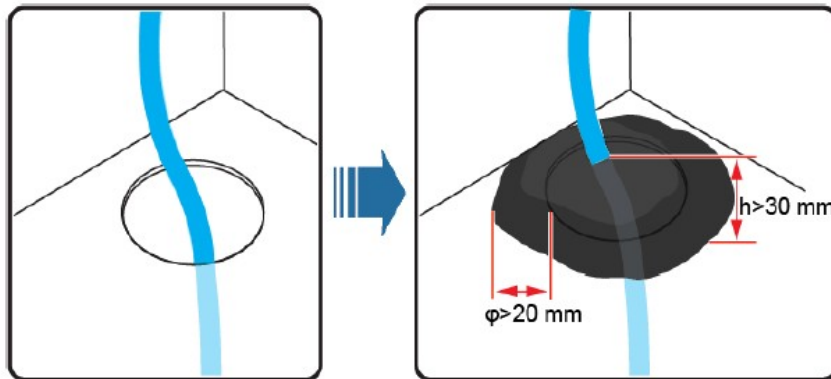

- Artificially altering, damaging, or covering the logos and nameplates on the equipment is strictly prohibited.
- When installing the device, use tools to tighten the screws.
- Operating with power on during the installation process is strictly forbidden.
- Paint scratches that occur during equipment transportation and installation must be repaired promptly. It is strictly forbidden to expose the scratched parts to the outdoor environment for an extended period.
- Before operation, securely fix the device to the floor or other stable objects, such as a wall or mounting bracket.
- Avoid using water to clean electrical components both inside and outside the cabinet.
- Do not alter the equipment's structure, installation sequence, or other aspects without authorization.

Personal safety

- During equipment operation, if a fault is detected that may cause personal injury or equipment damage, the operation should be stopped immediately, reported to the person in charge, and effective protective measures should be taken.
- To prevent the risk of electric shock, connecting safety extra-low-voltage (SELV) circuits to telecommunication network voltage (TNV) circuits is prohibited.
- Do not power on the device until the installation is complete and a professional has confirmed it.

1.2 Requirements for personnel

- Personnel responsible for installing and maintaining Kstar equipment must first undergo rigorous training, comprehend various safety precautions, and master the correct operating methods.
- Only qualified professionals or trained personnel may install, operate, and maintain the equipment.
- Only qualified professionals are permitted to remove safety features and repair equipment.
- Personnel who operate the equipment, including operators, trained personnel, and professionals, should have the special operation qualifications required by the local country, such as high-voltage operation, height climbing, and special equipment operation qualifications.
- Professional: A person experienced in training or operating equipment, who understands the various potential sources and magnitude of danger during the installation, operation, and maintenance of equipment.
- Trained personnel: Personnel who have received appropriate technical training and possess the necessary experience. They are aware of the potential dangers associated with performing certain operations and can take measures to minimize risks to themselves and others.
- Operator: An operator who may come into contact with the equipment, aside from trained personnel and professionals.
- Replacement of equipment or parts (including software) must be carried out by professional or authorized personnel.
- Unauthorized professional technicians are prohibited from removing the battery pack top cover.

1.3 Electrical safety

Grounding requirements

- When installing equipment that needs grounding, the protective earth wire must be installed first. When removing the equipment, remove the protective earth wire last.
- Avoid damaging the grounding conductor.
- Ensure the grounding conductor is installed before operating the equipment.
- The equipment must be permanently connected to a protective earth. Before operating the equipment, check its electrical connection to ensure it is reliably grounded.

General requirements

- When working with high-voltage, always use specially insulated tools.

AC and DC operation requirements



It is forbidden to install or remove the power cord with power on. The core of the power cord may produce an arc or spark upon contact with the conductor, potentially causing fire or personal injury.

- If the device is labeled with a "Large Leakage Current" mark, the protective grounding terminal of the device housing must be grounded before connecting the AC input power supply. This prevents the leakage current from causing electric shock.
- Before installing or removing the power cord, ensure the power switch is turned off.
- Before connecting the power cord, ensure that the power cord label is correctly

- marked.
- If the device has multiple inputs, all inputs should be disconnected, and the device can be operated only after it is completely powered off.
 - It is not recommended to configure a circuit breaker with a leakage protection function.
 - If the power cord is damaged, it must be replaced by the manufacturer, business agent, or a professional to avoid risks.
 - Personnel performing high-voltage operations and installing AC equipment must possess qualifications for high-voltage and AC work.

Wiring requirements

- Using cables in high-temperature environments may lead to the aging and damage of the insulation layer. The cables should be positioned at least 30 mm away from heating devices or the periphery of heat source areas.
- Cables are not allowed to pass through the air inlet and outlet of the equipment.
- Cables must meet VW-1 flame retardant grade requirements.
- Cables of the same type should be bundled together, while cables of different types should be laid at least 30mm apart. They must not be entangled or crossed.
- When the temperature is too low, severe impact and vibration can cause the plastic sheath of the cable to crack in a brittle manner. To ensure construction safety, adhere to the following requirements:
 - All cables should be laid and installed at temperatures above 0°C. When moving cables, especially in low-temperature environments, they should be handled with care.
 - If the storage temperature of the cables is below 0°C, they must be moved to room temperature and stored for over 24 hours before being laid out.
 - It is prohibited to perform irregular operations, such as directly pushing the cables off the vehicle.
 - The selection, connection, and routing of cables must adhere to local laws, regulations, and specifications.

Anti-static requirements

NOTICE

Static electricity generated by the human body can damage electrostatic-sensitive components on a single board, such as large-scale integrated circuits (LSI).

- Static electricity generated by the human body can damage electrostatic-sensitive components on a single board, such as large-scale integrated circuits (LSI). Before touching the equipment, holding a single board, or handling an application-specific integrated circuit (ASIC) chip, you must wear anti-static gloves or an anti-static wrist strap, ensuring the other end of the wrist strap is properly grounded.
- When holding a board, you must hold the edge without components and avoid touching the components with your hands.
- Disassembled boards must be packed in anti-static packaging materials before storage or transportation.

Neutral-to-ground voltage

- Users are recommended to balance the three-phase load to ensure the neutral-to-ground voltage is less than 2V, meeting the power distribution requirements.

1.4 Requirements for installation environment

- When the device is running, do not block the ventilation openings or cooling system to prevent a fire caused by high temperatures.
- The device should be installed in a location away from liquids. Installing it under water pipes, air outlets, or other areas prone to condensation is prohibited. It is forbidden to install it beneath the A/C port, vent, machine room outlet window, or other areas prone to water leakage, to prevent liquid from entering the equipment and causing failure or short circuit.
- If you find that liquid has entered the device, please turn off the power immediately and notify the administrator.
- Placing the device in an environment with flammable or explosive gas or smoke is prohibited, as is performing any operation in such an environment.
- The equipment should be installed away from deserts and dusty areas.

High altitude installation

- Work done more than 2 meters above the ground is considered high-altitude work.
- If any of the following situations occur, work at height should be halted: the steel pipe is still wet from rainwater, or other conditions that may pose a danger. Once the situation is resolved, the safety director and relevant technical personnel must inspect all operating equipment and confirm approval before resuming operations.
- When working at height, local height operation regulations must be followed.
- You must undergo relevant training and obtain the necessary certificates before you can take up your post and perform high-altitude operations.
- Before working at height, ensure you thoroughly inspect the climbing tools and safety equipment, including safety helmets, safety belts, ladders, springboards, scaffolding, and lifting equipment. If any items fail to meet the requirements, promptly improve them or refuse to work at height. Ensure proper safety measures by wearing a helmet, safety belt, or waist rope. Fasten it to a solid structural member. It is strictly forbidden to attach it to an unstable object or metal with sharp edges and corners to prevent the hook from slipping and falling.
- At high-altitude work sites, dangerous restricted areas should be clearly marked, with signs strictly prohibiting unauthorized personnel from entering.
- Handle operating equipment and tools with care to prevent them from falling and causing injury to others.
- Workers working at heights are strictly forbidden from throwing objects to the ground, and it is also strictly forbidden to throw objects from the ground to high altitudes. Objects should be transported using strong ropes, hanging baskets, elevated vehicles, or cranes.
- Guardrails and signs should be installed at the edges and openings of high-altitude work areas to prevent people from falling into empty spaces.
- Stacking scaffolding, springboards, and other debris on the ground below the aerial work area is strictly prohibited. Ground personnel are strictly prohibited from staying or passing under the high-altitude operation area.
- Scaffolding, springboards, workbenches, etc. used for aerial work must be inspected and appraised for safety in advance to ensure the structure is solid and the scaffolding is not overloaded.
- If the on-site supervisor or safety officer observes that construction workers working at heights are not following regulations, they should promptly address the issue and instruct them to make corrections. Otherwise, its operation must be stopped.

1.5 Safety of machinery

Lifting safety

- When lifting heavy objects, walking under the crane arm or the lifted object is strictly forbidden.
- Personnel performing lifting operations must undergo relevant training and obtain qualifications before taking up their posts.
- Lifting tools must be inspected and fully assembled before use.
- Before lifting, ensure the lifting tools are securely attached to a load-bearing object or wall.
- During the lifting process, make sure the angle between the two cables does not exceed 90° , as illustrated in the figure below.

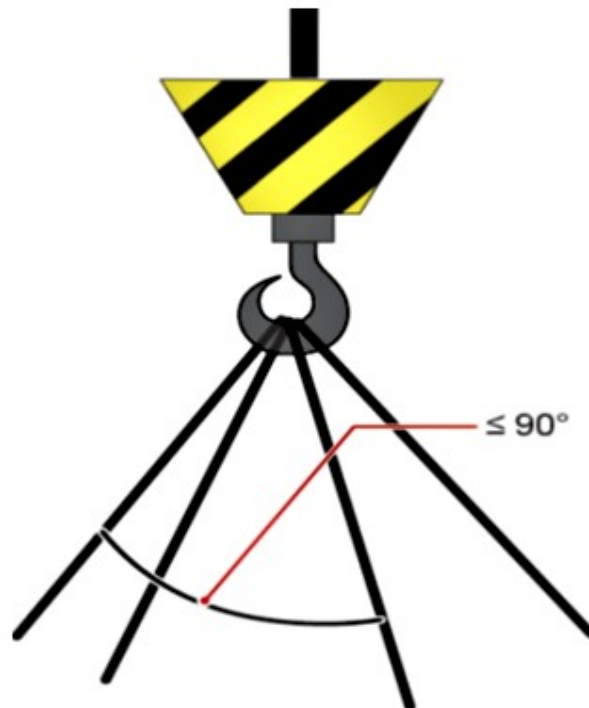

- During lifting, dragging the wire rope or lifting equipment is prohibited, as is using hard objects to strike them.

Safe use of ladders

- When electrical work is involved, wooden or fiberglass ladders should be used.
- When using a stepladder, ensure the draw rope is secure and have someone hold the ladder while you work.
- Before using a ladder, ensure it is intact and its load-bearing capacity meets the requirements. Using the ladder while overloaded is strictly prohibited.
- The ladder should be placed on a stable surface. The ladder's gradient should be 75° , which can be measured with an angle square, as shown in the figure below. Ladders should be used with the wide legs facing downwards or with protective measures at the bottom to prevent slipping.

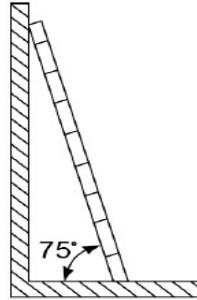

- When climbing a ladder, focus on the following actions to minimize risk and ensure safety.
- Keep your body steady.
- The operator's feet should not stand higher than the 4th step from the top of the ladder.
- Ensure your center of gravity remains close to the edge of the ladder.

Safety of drilling

- The following safety precautions should be taken into account when drilling holes in walls or on the ground:

NOTICE

Drilling holes in the equipment is strictly prohibited. Drilling will damage the electromagnetic shielding performance of the equipment, internal components, and cables. Additionally, the metal chips generated by drilling will enter the equipment and cause a short circuit on the circuit board.

- Consent must be obtained from the customer, contractor, and Kstar before drilling.
- When drilling, wear goggles and protective gloves.
- The equipment should be shielded during the drilling process to prevent debris from falling into it. The debris should be cleaned up promptly after drilling.

Safe handling of heavy objects

DANGER

When removing equipment from the cabinet, be careful to avoid crushing or damaging any unstable or heavy items.

- When carrying heavy objects, be prepared to support the weight to avoid being crushed or sprained.

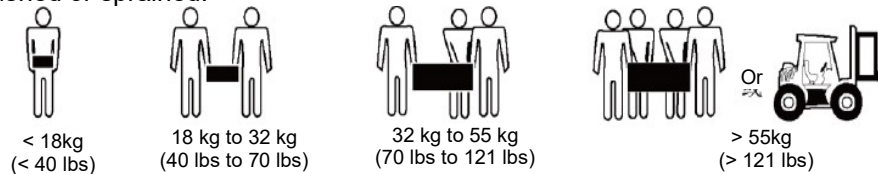

- Wear protective gloves to prevent injury when carrying the equipment by hand.
- When moving or lifting the device, hold it by its handles or bottom edge, not by the handles of installed modules.
- When moving the equipment, avoid scratching the cabinet surface or damaging its components and cables.
- When transporting with a forklift, ensure the forks are in the middle position to prevent tipping over. Before moving, please secure the equipment to the forklift using a rope. When moving, special care is required.

- When transporting, you should opt for rail transportation, sea transportation, or roads with good conditions to ensure the safety of the equipment. Bumps and tilts should be minimized during transport.
- Be careful when moving the cabinet to avoid any impacts or drops that may damage the equipment.

1.6 Battery safety

Basic requirements

Before operating the battery, you must carefully read the safety precautions and understand the correct method for connecting the battery.

⚠ DANGER

Do not expose the battery to high temperatures or heating devices such as sunlight, fire, transformers, heaters, etc. Overheating of the battery can lead to an explosion.

Burning the battery is strictly forbidden, as it may cause an explosion.

Disassembling, modifying, or damaging the battery (such as inserting foreign objects or immersing it in water or other liquids) is strictly forbidden to prevent battery leakage, overheating, fire, or explosion.

- Wear goggles, rubber gloves, and protective clothing to prevent hazards caused by electrolyte overflow. If the battery leaks, avoid contact between the leaked liquid and your skin or eyes. If contact occurs, rinse the affected area with clean water immediately and seek medical treatment at a hospital.
- Please use tools that are specially insulated.
- When transporting batteries, ensure they are oriented as specified. It is strictly prohibited to carry them upside down or tilted.
- During installation, maintenance, and other operations, the battery circuit must remain disconnected.
- Please use the specified battery type. Using any other type of battery may cause damage.
- Please dispose of used batteries according to local laws and regulations. Do not treat batteries as household waste. Improper disposal of the battery can lead to an explosion.
- The site must be equipped with fire-fighting facilities that meet the requirements, including fire sand and dry powder fire extinguishers.

NOTICE

To ensure safe battery usage and accurate battery management functions, please use the battery provided by Kstar with the PCS host. Kstar is not responsible for battery-related faults caused by using batteries not configured by Kstar.

Battery installation specifications

- Before installing the battery, ensure safety by paying attention to the following basic precautions:
- The battery should be installed in a well-ventilated, dry, and cool environment, away from heat sources, flammable materials, moisture, environments with significant infrared radiation, organic solvents, and corrosive gases. Fire prevention measures should also be taken. The battery shall be placed horizontally and fixed.
- When installing a battery, pay attention to its positive and negative poles. It is strictly forbidden to short-circuit the positive and negative poles of the same battery or group of batteries, as this will result in a battery short circuit.
- Regularly check the battery terminal screws to ensure they are tight and secure.
- Placing installation tools on the battery during installation is strictly forbidden.

Battery short circuit protection

 **DANGER**

A short circuit in the battery will produce an instantaneous high current and release a large amount of energy, which may cause personal injury and property damage.

To avoid a battery short circuit, the battery must not be maintained online.

Lithium battery special scene

The safety precautions for lithium battery operation are similar to those for lead-acid batteries, and the following matters need to be noted.

 **WARNING**

Replacing the battery with an incorrect model poses a risk of explosion.

- Replace only with the same type or a similar type recommended by the manufacturer.
- When transporting lithium batteries, avoid inverting, tilting, or colliding with them.
- During installation, maintenance, and other operations, the lithium battery module circuit must remain disconnected.
- When the lithium battery is below the lower limit of the operating temperature, charging is forbidden (charging is forbidden at 0°C) to avoid an internal short circuit caused by crystallization from low-temperature charging.
- Avoid exceeding the temperature range, as it will impact battery performance and safety.
- Do not throw lithium battery modules into a fire.
- After maintenance is completed, the used lithium battery module should be returned to the maintenance site.

1.7 Other

Transportation, storage and maintenance

- During long-term storage, the battery must be charged and discharged once every 6 months as specified in the specification.
- Be careful not to drop the battery when loading and unloading it during transportation. Ensure it faces up and do not turn it over.

Warnings and Precautions

Before using the battery, please carefully read the specifications and warning signs on the

battery box surface. Improper use may lead to overheating and damage. Shenzhen KSTAR New Energy Co., Ltd. assumes no responsibility for accidents resulting from non-compliance with the specifications. To ensure safe use and handling, please read the operating instructions thoroughly before use.

2 Overview

2.1 Battery system parameters

2.1.1 Cell parameters

| NO. | Item | Characteristic |
|-----|-----------------------------------|----------------|
| 1 | Cell type | LFP |
| 2 | Nominal voltage | 3.2V |
| 3 | Rated capacity | 280Ah |
| 4 | Rated energy | 896Wh |
| 5 | Maximum continuous charging rate | 0.5C |
| 6 | Recommended charging rate | ≤0.5C |
| 7 | Maximum continuous discharge rate | 0.5C |
| 8 | Recommended discharge rate | ≤0.5C |

2.1.2 Battery module parameters

| NO. | Item | Characteristic |
|-----|----------------------|----------------|
| 1 | Series-parallel mode | 20S1P |
| 2 | Rated voltage | 64V |
| 3 | Rated capacity | 280Ah |

| | | |
|---|--|--|
| 4 | Rated energy | 17.92kWh (BC107DE2 series) 16.12kWh (BC96DE2-AU series) |
| 5 | Rated charging voltage | 72V |
| 6 | Recommended charging and discharging current | ≤140A @25±5°C |
| 7 | Weight | About 139Kg |

Instructions for charging the battery module:

If the customer needs to charge a separate battery module, the charger must be set strictly according to the recommended values of the battery module parameters mentioned above; otherwise, the battery module may be easily damaged.

2.1.3 Parameters of battery cabinet

| Item | Characteristic | | | | | |
|---|---|----------|---------------|----------|---------------|-----------|
| | BC63DE2-AU | BC70DE2 | BC80DE2-AU | BC89DE2 | BC96DE2-AU | BC107DE2 |
| Total energy | 64.51kWh | 71.68kWh | 80.64kWh | 89.60kWh | 96.76kWh | 107.52kWh |
| Rated voltage | 256VDC | | 320VDC | | 384VDC | |
| Recommended depth of discharge | 90% | | | | | |
| Operating voltage range | 228VDC–288VDC | | 285VDC–360VDC | | 342VDC–432VDC | |
| Number of battery clusters/cabinet | 1 | | | | | |
| Rated charging current | 140A (0.5C) | | | | | |
| Rated discharge current | 140A (0.5C) | | | | | |
| Monitoring parameters | Battery cluster voltage, current, cell voltage, cell temperature, ambient temperature, etc. | | | | | |
| Mode of communication | CAN/Ethernet/RS485 | | | | | |
| Operating ambient temperature range | -30°C - +50°C | | | | | |
| Storage temperature range | -30°C - +60°C (25°C recommended for long-term storage) | | | | | |
| Relative humidity | 5%~95%, non-condensing | | | | | |
| Temperature control mode | A/C cooling or heating | | | | | |
| Net weight | About 1165Kg | | About 1300Kg | | About 1435Kg | |
| Product size | W1062mm*D1371mm*H2083mm (including A/C and lifting ring) | | | | | |
| Degree of protection | IP54 | | | | | |
| Recommended altitude | ≤3000m | | | | | |
| AC input condition short circuit current (I _{cc}) | 6kA | | | | | |
| Current of external protection device | 20A | | | | | |
| Maximum short-circuit current and time | 2.61kA/1.068ms | | | | | |
| Noise level | ≤70dB | | | | | |
| Capacity of transportation | ≤40%SOC | | | | | |

2.1.4 High voltage box interface

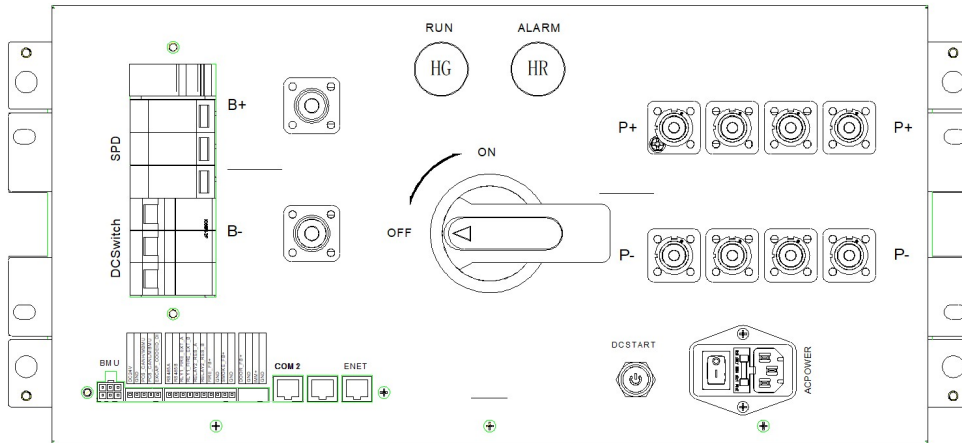

Figure 2-1 Panel of HVB

Panel component definition:

| Port | Description of port |
|-------------------|--|
| P+ | DC output positive |
| P- | DC output cathode |
| B+ | Positive pole of series battery module |
| B- | Negative pole of series battery module |
| DC START | DC start button/black start button |
| AC POWER | 220VAC input |
| RUN | Running indicator lamp |
| ALARM | Alarm indicator lamp |
| Handle of breaker | DC system switch |
| DC Switch | DC power switch |
| SPD | Lightning protection module |

Definition of weak current/communication port:

| Port | Description of port |
|---------------|---|
| PCS_CAN/MBMU | CAN interface communication of PCS or CAN interface |
| RLY_FIRE_EXT | Reserved dry contact 1 |
| BMU | Battery module information exchange interface |
| 24VOUT | 24V power output port |
| RELAY2_RES | Reserved dry contact 2 |
| RS485A/RS485B | A/C communication interface |
| FIRE_FB+ | Fire control feedback input |
| SMOKE_FB+ | Reserved feedback |
| DOOR_FB+ | Door status detection |
| IMM+ | Water immersion test |
| GND | One GND for each FB+ signal and 24V |

Description of RJ45

| RJ45 port | Description of port |
|-----------|--|
| COM1 | CAN input line of cabinet paralleling (first cabinet suspended) |
| COM2 | CAN output line of parallel cabinet (terminal resistance of end cabinet connected to 120Ω) |
| ENET | Ethernet, 100M Ethernet, network port |

BMU interface

| | |
|---------------|--|
| +24V | BMU power supply input |
| GND | |
| BMU_CANH | CAN communication |
| BMU24V_START | BMU24V enable |
| BMU_CODEID_DO | Auto-coding hardware flag bit (output) |
| BMU_CANL | CAN communication |

2.1.5 Switch interface (Optional)

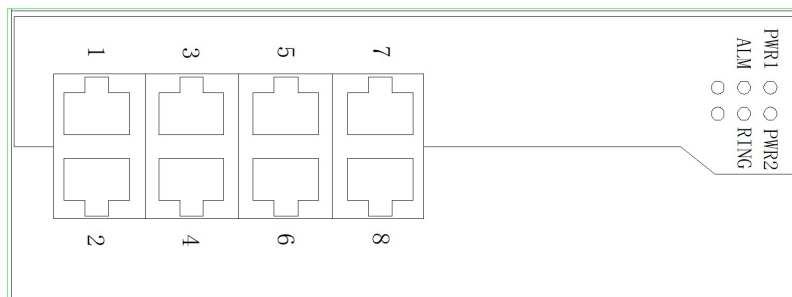

Figure 2-2 Switch panel

Switch interface

| | |
|---|-------------------|
| 1 | EMS communication |
|---|-------------------|

| | |
|---|--------------------|
| 2 | MBMU communication |
| 3 | Reserved |
| 4 | Reserved |
| 5 | Reserved |
| 6 | Reserved |
| 7 | Reserved |
| 8 | Reserved |

2.1.6 MBMU interface

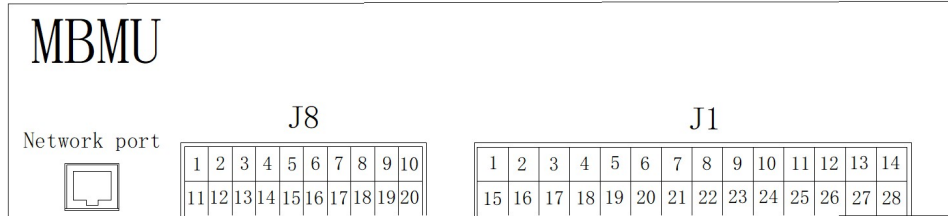

Figure 2-3 MBMU panel

| MBMU interface | | |
|----------------|----------------------|---|
| Port | Serial number of pin | Definition |
| Network port | | Ethernet communication |
| J8 | 1 | Safety valve 2 actuation |
| | 2 | |
| | 3 | Safety valve 1 actuation |
| | 4 | |
| | 5 | Audible and visual alarm |
| | 6 | |
| | 7 | Power supply dry contact of safety valves 1 and 2 |
| | 8 | |
| | 9 | Safety valve 1 feedback |
| | 10 | |
| | 11 | Safety valve 2 feedback |
| | 12 | |
| | 15 | Emergency stop feedback |
| 16 | | |
| 17 | Smoke feedback | |
| 18 | | |
| 19 | CO alarm | |
| 20 | | |
| J1 | 1 | MBMU power supply 24V+ |
| | 2 | MBMU power supply GND |
| | 3 | CO alarm power supply |
| | 4 | CO alarm GND |
| | 5 | AC Trip/Safety Valve Power Supply |
| | 6 | Exhaust fan/audible and visual alarm power supply |
| | 7 | Safety valve GND |
| | 8 | Audible and visual alarm GND |

| | | |
|--|----|-----------------|
| | 9 | AC trip GND |
| | 12 | Exhaust fan GND |
| | 13 | CANH1 (SBMU) |
| | 14 | CANL1 (SBMU) |
| | 15 | CANH2 (PCS) |
| | 16 | CANL2 (PCS) |

2.1.7 Charge and discharge curve

1. Relationship curve between charging current and voltage: voltage below 2.5V: charging according to 0.1C current; voltage 2.5V-3.45V: charging according to 0.5C current; voltage above 3.45V: charging power needs to be derated; when the voltage reaches 3.55V, charging current is 0. A more intuitive plot of the charging current limit versus voltage is shown below.

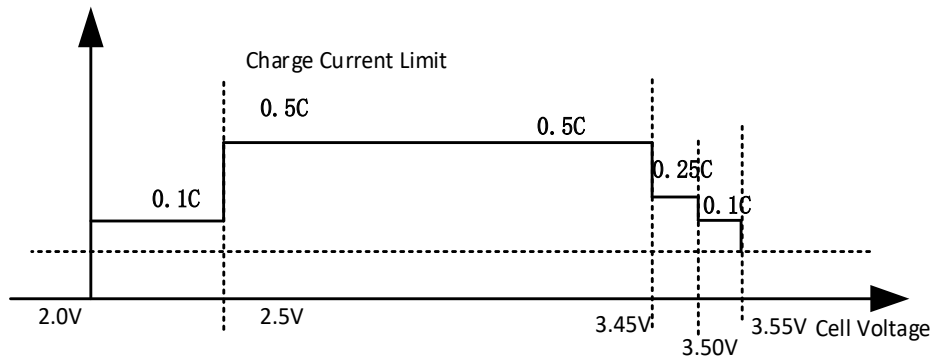

Figure 2-4: Relationship curve between charging current limit and voltage

2. The relationship curve between discharge current and voltage: When the voltage reaches 3.05V, the discharge current is 0. A more intuitive plot of the discharging current limit versus voltage is shown below.

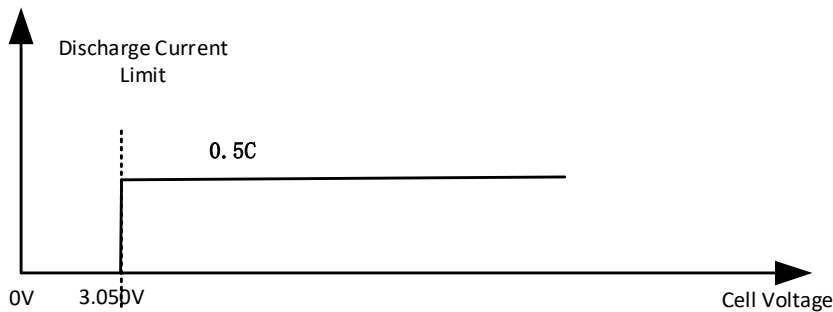

Figure 2-5: Relationship curve between discharge current limit and voltage

3. Relationship curve between charging current and temperature: below 22°C: according to the charging requirements of battery specifications, the relationship curve between charging current limit and temperature is formulated; above 45°C: the charging power

needs to be derated; when the temperature reaches 60°C, the charging current is 0. Refer to the graph below for a clearer understanding of the relationship between the charging current limit and temperature.

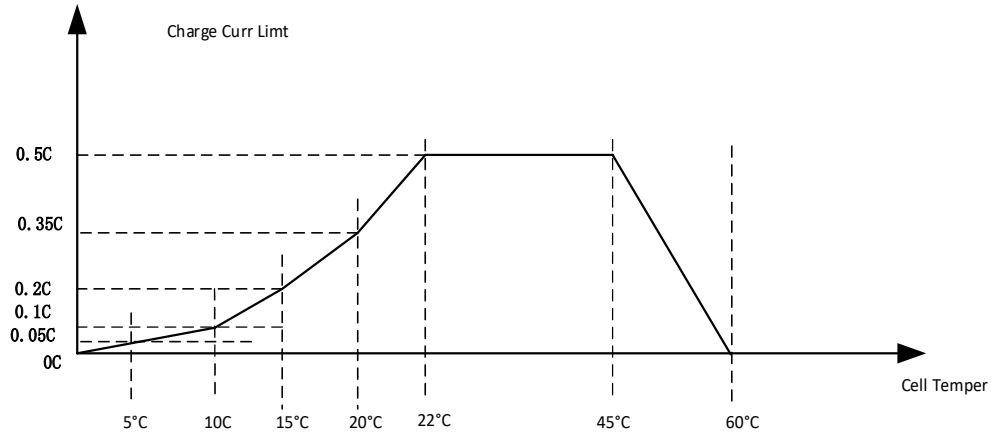

Figure 2-6: Relationship curve between charging current limit and temperature

4. Relationship curve between discharge current and temperature: the temperature is between -10°C and 45°C, and the discharge current is limited to 140A. When the temperature exceeds 45°C, the discharge current needs to be derated, and when the temperature reaches 55°C, the discharge current is limited to 0. Below is a more intuitive plot of the discharge current limit versus temperature.

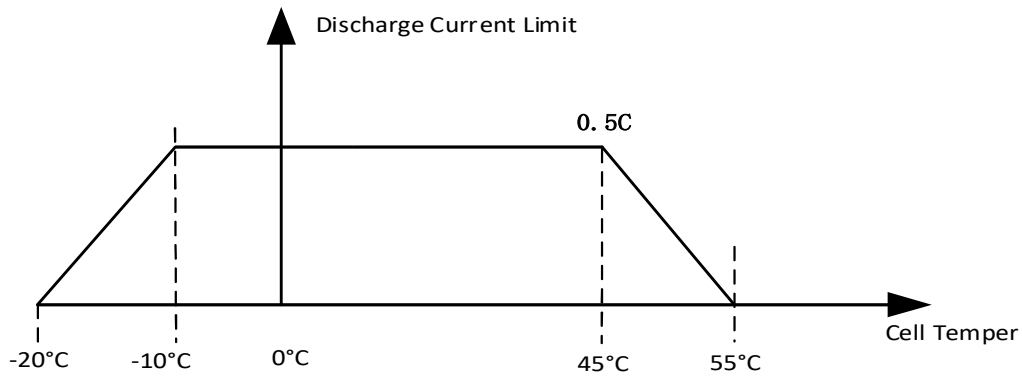

Figure 2-7: Relationship curve between discharge current limit and temperature

2.2 Product introduction

Industrial and commercial battery cabinets contain HVBs and battery modules, as well as EMS, BMU, SBMU, MBMU, and other modules. These components can store and release electric energy according to the requirements of the EMS energy management system. The B+, B-, P+, and P- ports of the HVB in the industrial and commercial battery cabinets are all high-voltage DC.

- Battery charging: The P+ and P- ports of the battery cabinet HVB connect to the energy storage terminal (BAT+, BAT-) of the energy storage converter. The energy storage converter controls the charging process, transferring energy from the PV system or mains supply into the battery.

- Battery discharge: When PV energy is insufficient to power the load, the system must control the battery to supply power to the load and output the stored battery energy through the energy storage converter.

2.2.1 Product appearance



(1) Main view of battery cabinet



(2) Side view of battery cabinet

Figure 2-8 Schematic diagram of battery cabinet

The main battery cabinet includes the following functions: battery cluster management, communication with PCS, display and storage of all system data, EMS management, and modification of system parameters. The main battery cabinet's front door features an EMS display screen.

2.2.2 Product structure

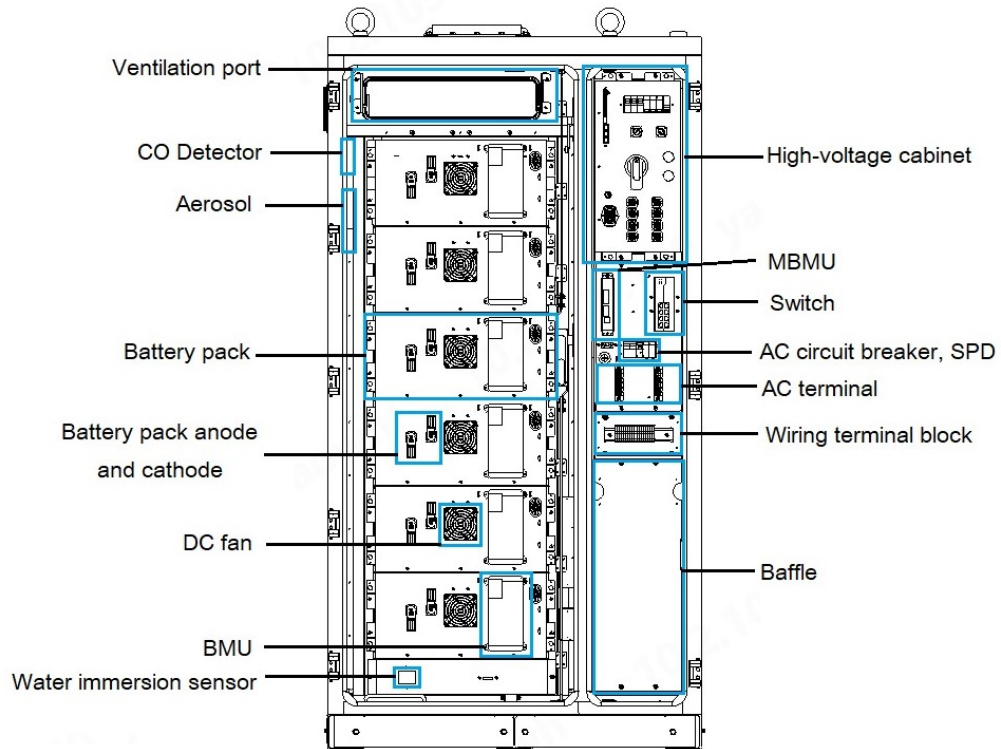

Figure 2-9 BC107DE2 Internal Cabinet Structure

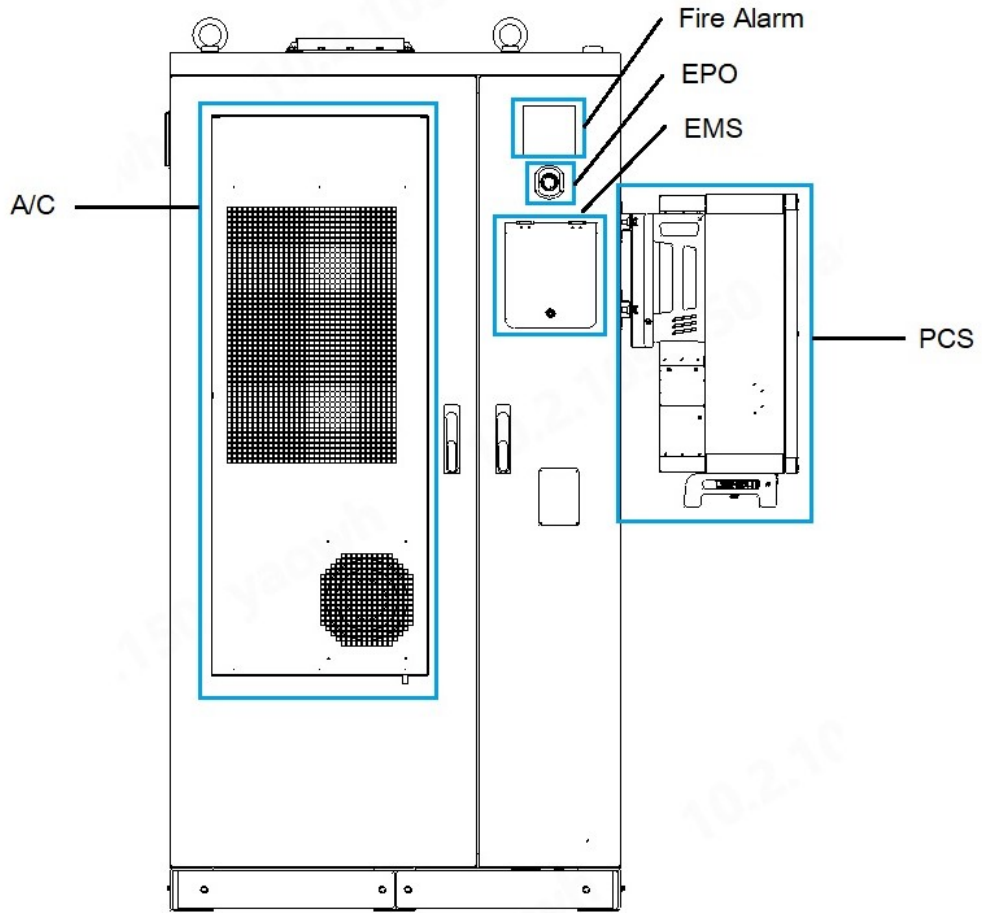

Figure 2-10 BC107DE2 External Structure

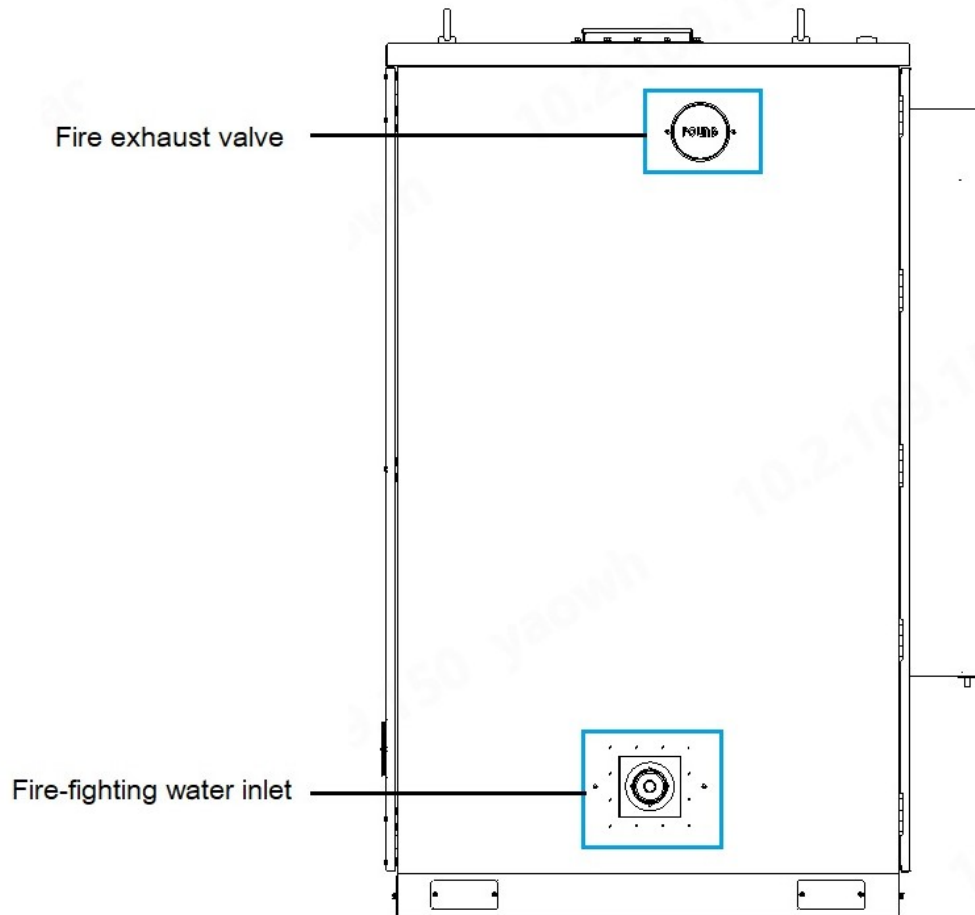

Figure 2-11 BC107DE2 Left-Side Structure

2.2.2.1 High voltage box

The HVB is the switching and protection device for the battery-cluster output. Its internal components mainly include DC contactors, DC fuses, circuit breakers, shunts, and the battery-cluster BMS.

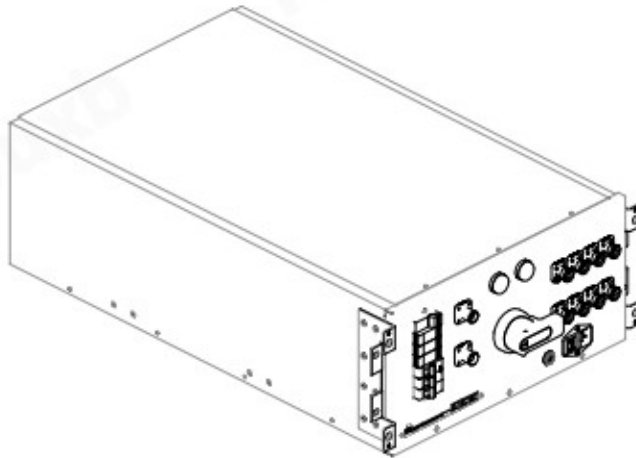

Figure 2-12 HVB

Functions

(1) Connection and disconnection control

The main contactors (positive and negative contactors) connect and disconnect the battery-cluster high-voltage circuit, enabling the battery cluster to enter or exit operation and supporting start/stop control for charging and discharging.

(2) Pre-charge management

The HVB is equipped with a pre-charge resistor and pre-charge contactor. Before the battery cluster enters operation, the pre-charge circuit slowly charges the bus capacitor to suppress inrush current during closing and protect core components such as contactors, fuses, and the PCS from impact damage.

(3) Fault protection

- Short-circuit protection: When severe faults such as short circuits or overcurrent are detected, the fuse or circuit breaker quickly disconnects the high-voltage circuit to prevent fault escalation and protect the battery cluster and external equipment.
- Overvoltage/undervoltage protection: The system monitors the battery-cluster voltage and triggers protection when the voltage exceeds the safe range, preventing overcharge or overdischarge.
- Insulation monitoring: The system monitors the insulation status of the high-voltage circuit to ground in real time and issues an alarm or disconnects the circuit if insulation degradation or leakage risk is detected.

(4) Parameter monitoring and data acquisition

Built-in sensors, including voltage, current (shunt), and NTC sensors, collect battery-cluster voltage, current, temperature, and other parameters in real time. These data support the battery management system (BMS) and energy management system (EMS) for battery status monitoring, charge/discharge control, and fault diagnosis.

(5) Emergency isolation and maintenance support

The HVB is equipped with a circuit breaker that can manually disconnect the high-voltage circuit during emergencies or maintenance, providing physical isolation to protect operation and maintenance personnel and facilitate service work.

The dimensions of the HVB are as follows:

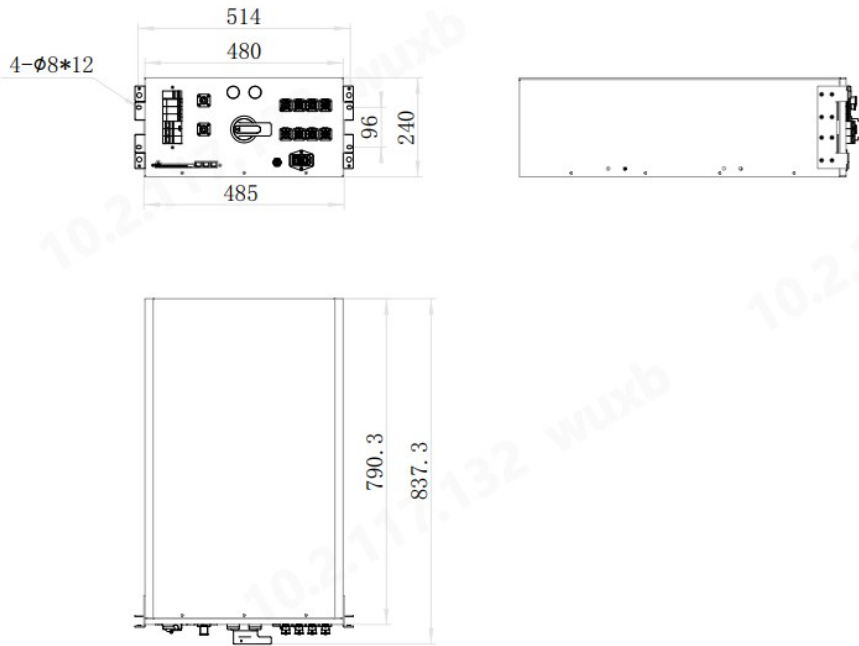

Figure 2-13 Dimension of HVB (mm)

2.2.2.2 MBMU

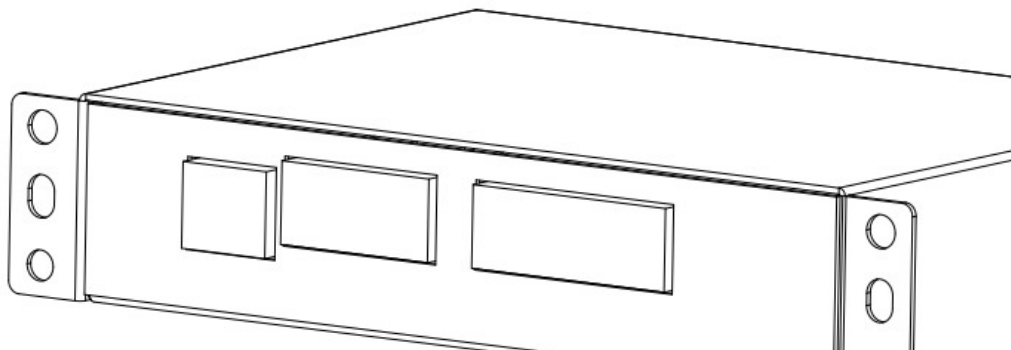

Figure 2-14 MBMU

Function:

The MBMU communicates with the SBMU, PCS, and EMS, and receives feedback signals from the safety valve, emergency stop switch, smoke sensor, and CO sensor to execute the corresponding system operation strategy.

The dimensions of the MBMU are as follows:

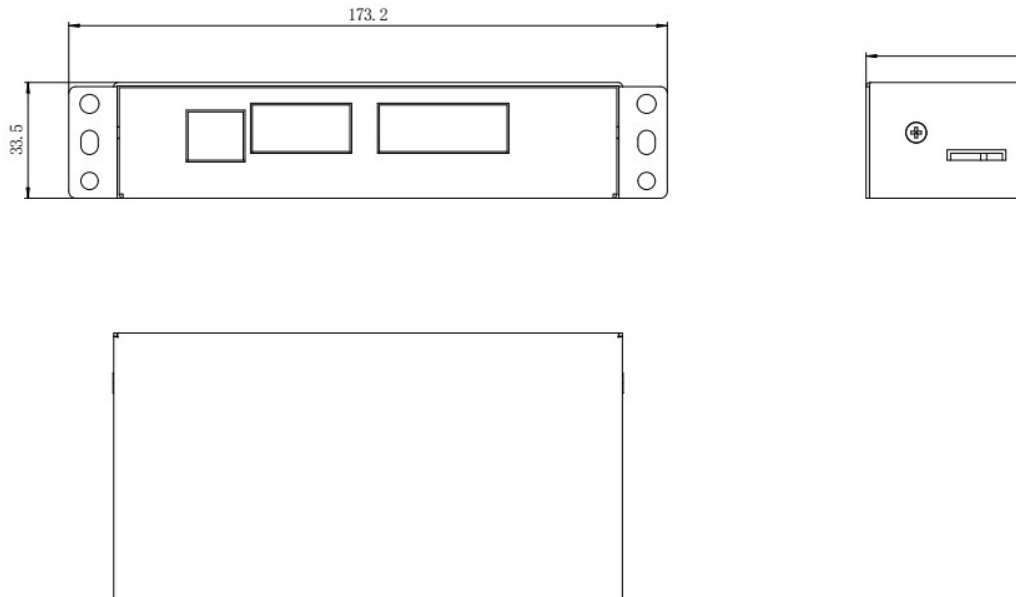

Figure 2-15 Dimension of MBMU (mm)

2.2.2.3 Battery module

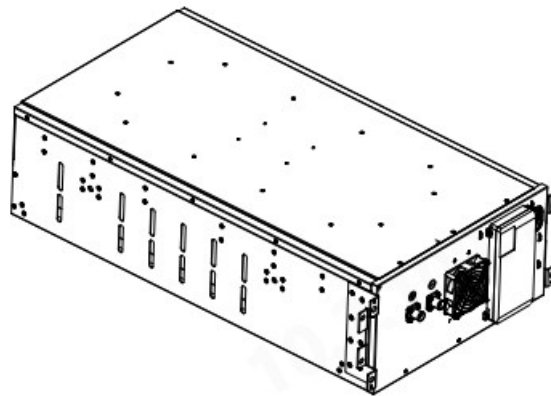

Figure 2-16 Battery module

Functions

The battery module consists of cells and serves as the power source for the entire system. The BMU unit, configured with the battery module, collects the voltage, temperature, and other information from the lithium battery and uploads it to the SBMU control unit. The battery module is equipped with a fire-fighting unit for automatic fire extinguishing. The

battery module's dimensions are as follows:

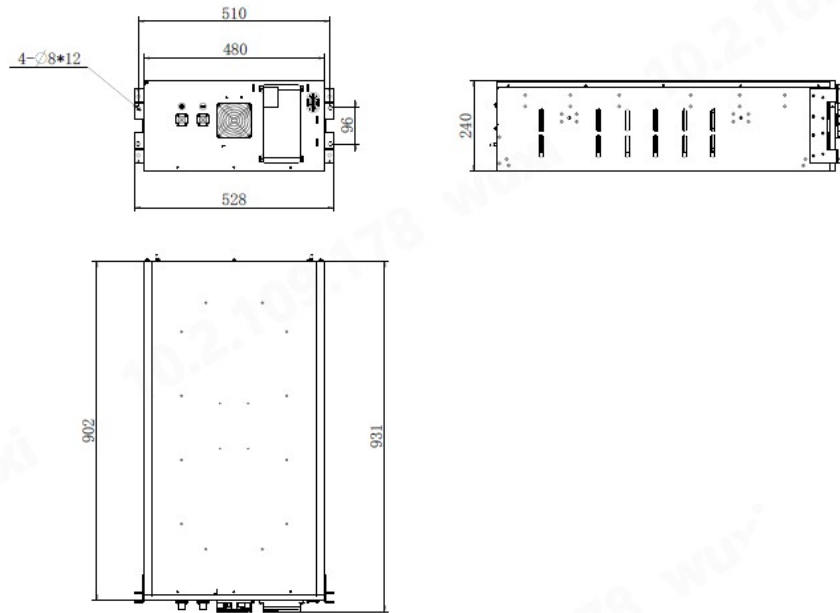

Figure 2-17 Dimensions of battery module (mm)

2.2.3 BC107DE2 Electrical Connection Diagram

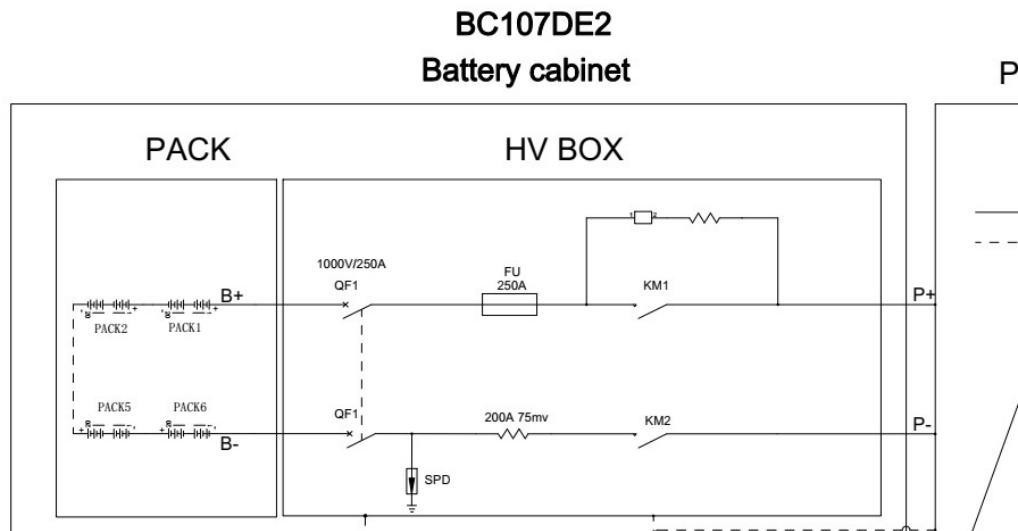

Figure 2-18 Electrical Connection Diagram (1)

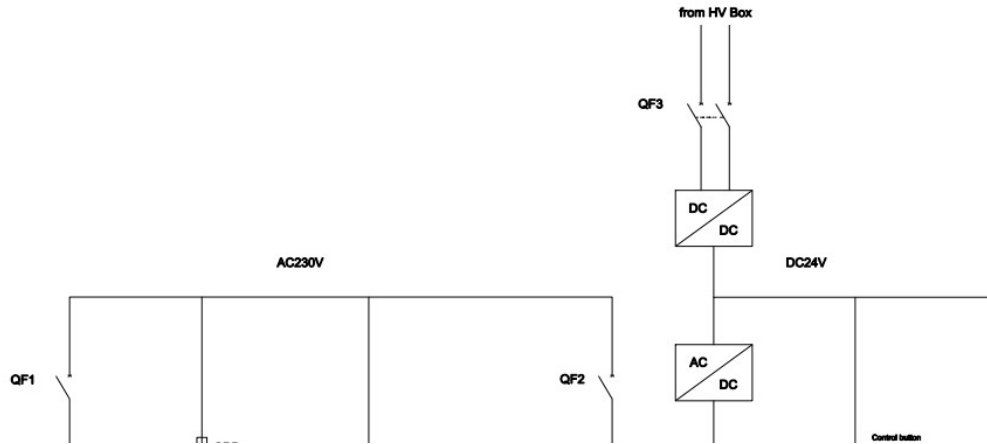

Figure 2-19 Electrical Connection Diagram (2)

2.2.4 Product model and naming rules

2.2.4.1 Naming rules for battery cabinet models:

| | | | | | | | | |
|---------|---|---------|---|---------|---|---------|---|---------|
| BC | - | 107 | - | D | - | E | - | 2 |
| Field 1 | | Field 2 | | Field 3 | | Field 4 | | Field 5 |

| Field 1 | Field 2 | Field 3 | Field 4 | Field 5 |
|--|-----------------------|----------------------------------|--|--|
| BC: Battery cabinet Industrial and commercial battery cabinet | Energy 107: 107kWh | D: Outdoor Vacancy: Indoor | E: With EMS unit Vacancy: without EMS unit | 2: The second generation of BC107DE fire upgrade |

2.2.4.2 Naming rules for battery module models:

BC - PACK - 17.92 - 20S - 140A
 | | | | |
 Field 1 Field 2 Field 3 Field 4 Field 5

| Field 1 | Field 2 | Field 3 | Field 4 | Field 5 |
|--|------------------------|---------------------------|----------------------------|--|
| BC: Battery cabinet Industrial and commercial battery cabinet | PACK Battery module | Energy 17.92: 17.92kWh | 20S: 20 cells in series | 140A: maximum current of the cell |

3 Installation

3.1 Site planning

3.1.1 Dimension of battery cabinet

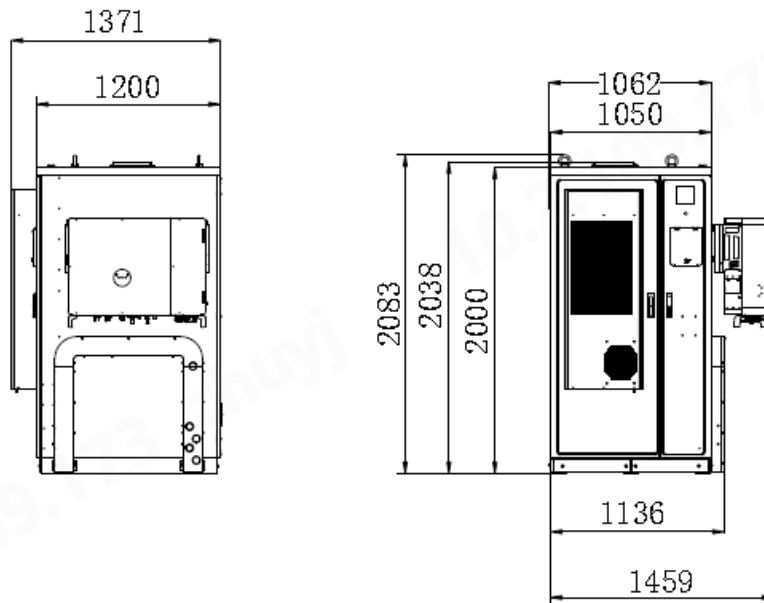

Figure 3-1 Dimensions of cabinet (mm)

3.1.2 Precautions for installation

Installing a fence around the battery cabinet is recommended to prevent unauthorized access.

Place the battery cabinet on level ground, ensuring it is stable and not shaking or tilting. When installing the battery cabinet, consider the bearing and load capacity of the ground and floor, as specified in the architectural drawings.

Do not cover the vents with objects to avoid hindering the heat dissipation of the battery cabinet, which could cause the internal temperature of the system to rise and affect the safety and lifespan of the battery.

Please ensure the installation environment of the battery cabinet is well-ventilated. Avoid installing it in areas with extreme temperatures, high humidity, water, flammable gases, corrosives, or heat sources. It is recommended to avoid direct sunlight and keep the inlet/outlet free of dust.

Please avoid using the battery cabinet in environments with dust, volatile gases, corrosive gases, or excessive salt. Do not place flammable or explosive materials near the battery cabinet.

To minimize the risk of fire and the damage it may cause, the walls, ceilings, and floors of the room housing the battery cabinet should be made of fireproof materials and equipped with portable dry powder fire extinguishers.

Please refer to the relevant safety regulations for installation.

3.1.3 Space reservation

A certain amount of operation and ventilation space shall be reserved around the cabinet.

- If the front door needs to be opened or repaired, it is recommended to leave 1200mm of ventilation and operating space.
- It is recommended to reserve 1200mm of operating space when installing PCS on the right side.
- Reserving a height of 400mm at the top is recommended.











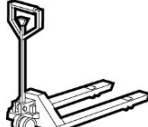



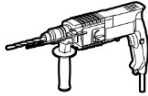
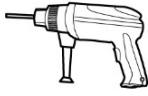
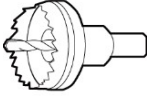

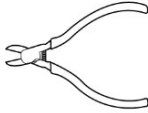
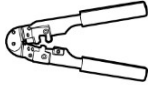
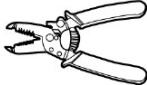

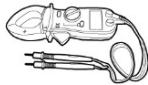



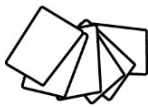
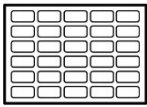

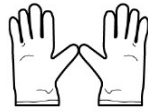
3.2 Preparation of tools and instruments

⚠ DANGER

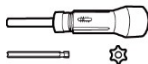
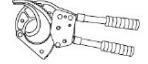
Use insulated tools to avoid electric shock.

Table 3-1 Preparation of tools and instruments

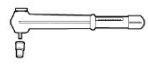
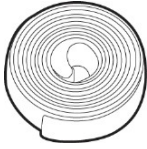
| Tools and gauges | | | |
|---|---|---|---|
| Electric forklift | Hand operated forklift | Ladder | Rubber hammer |
|  |  |  |  |

| | | | |
|---|---|---|---|
| Impact rotor | Hand-operated impact rotor | Alloy hole saw | Hot air gun |
|  |  |  |  |
| Diagonal cutting pliers | Crimping tool | Stripping forceps | Electrohydraulic pressure |
|  |  |  |  |
| Clamp-on ammeter | Multimeter | Cable tie | Measuring level |
|  |  |  |  |
| Insulating tape | Cotton cloth | Label | Electrical knife |
|  |  |  |  |
| Anti-static gloves | Lead rubber gloves | Thermal insulation gloves | Insulated protective shoes |
|  |  |  |  |
| Torque screwdriver | Cable scissors | Brush | Flat head screwdriver (2 - 5mm) |
|  |  |  |  |
| Phillips screwdriver (M3/M4/M5/M6/M8) | Insulated torque wrench (M6/M8/M12/M16) | Heat-shrinkable tube | Insulated adjustable wrench |
|  |  |  |  |
| Crane | | | |

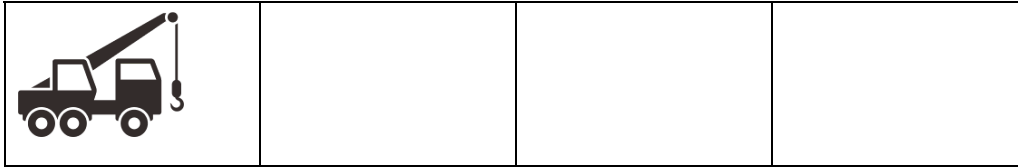

3.3 Remove the packaging

Operation steps

Step 1: Use a forklift to move the battery cabinet to the designated location.

Step 2: Take off the battery cabinet's outer packaging.

Step 3: Once you have confirmed the equipment is intact, remove the bolts securing the battery cabinet to the pallet and then move the battery cabinet off the pallet.

3.4 Single cabinet installation

3.4.1 Installation environment

- Do not install the battery cabinet in places with high or low temperatures, or in humid environments beyond the technical specifications.
- The battery cabinet should be kept away from water, heat sources, and flammable or explosive items.
- Do not install the battery cabinet in the desert or its surrounding environment.
- Do not install the battery cabinet in environments with direct sunlight, dust, volatile gases, corrosive substances, or excessive salt.
- Do not install the battery cabinet on an unstable or vibrating foundation.
- Installing the battery cabinet in a working environment with metallic conductive dust is strictly forbidden.
- The optimal temperature for the battery cells in the battery cabinet is 20°C to 30°C. Considering the cooling capacity of the A/C and the optimal working temperature of the battery cells, it is recommended that the ambient temperature of the battery cabinet not exceed 45°C. If the temperature exceeds 45°C, it is recommended to derate. For each 1°C increase, derate by 10% to maintain the optimal temperature of the cell in the cabinet. It is recommended that the maximum ambient temperature should not exceed 50°C. Prolonged exposure to temperatures exceeding 50°C can accelerate battery aging.

3.4.2 Installation of the cabinet

3.4.2.1 Installation site selection

When selecting the installation site, please adhere to at least the following principles:

- The climatic environment, geological conditions (such as stress wave emission and groundwater level), and other characteristics of the installation site for the integrated energy storage system must be fully considered.
- The surrounding environment is dry, well-ventilated, and far from flammable and explosive areas.
- The soil at the installation site must be compacted to a certain degree. It is recommended that the soil's relative density at the installation site be $\geq 98\%$. If the soil is loose, take measures to ensure the foundation remains stable.

3.4.2.2 Foundation requirements

⚠ WARNING

The integrated energy storage system is relatively heavy overall, so a detailed investigation of various conditions at the installation site—primarily geological, environmental, and climatic conditions—should be conducted before the foundation is constructed. The design and construction of the foundation can only begin on this basis.

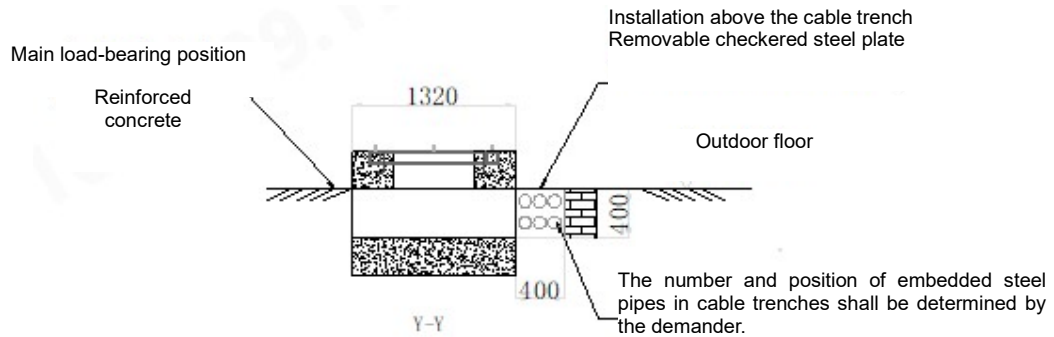

Figure 3-2 Reference front view of battery cabinet installation foundation

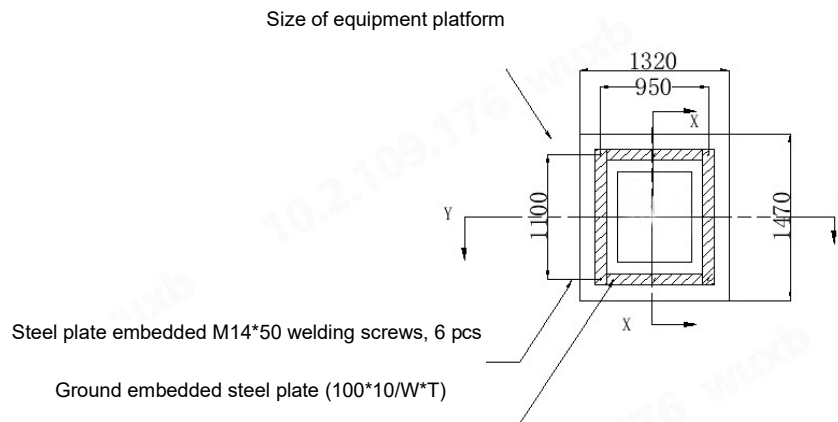

Figure 3-3 Reference top view of battery cabinet installation foundation

- An unreasonable foundation construction scheme can cause significant difficulties or troubles for the placement, door operation, and subsequent functioning of the energy storage integrated system. Therefore, the installation foundation for these systems must be designed and constructed in advance according to specific standards to meet the requirements for mechanical support, cable routing, and future maintenance.

- The foundation must be constructed to meet at least the following requirements:
 - The bottom of the foundation pit, where the foundation is constructed, must be tamped and filled.
 - The foundation must be sufficient to provide effective load-bearing support for the integrated energy storage system.
 - Elevate the integrated energy storage system to prevent rainwater from eroding its base and interior. It is recommended that the foundation be approximately 300 mm above the level ground at the installation site.
 - The corresponding drainage measures should be constructed in accordance with the local geological conditions.
 - Construct cement foundations with sufficient cross-sectional area and height. The construction party shall determine the foundation height based on the site geology.
 - The foundation should be constructed with consideration for cabling.
 - The maintenance platform is designed on a solid foundation to ease future maintenance.
 - Based on the position and size of the cable inlet and outlet on the outdoor battery cabinet, sufficient space must be reserved for the AC/DC side cable trough during the foundation construction, and the cable conduit must be embedded in advance.
 - The specification and quantity of perforated tubes will be determined based on the cable model and the number of incoming and outgoing lines.
 - Both ends of all embedded pipes are temporarily sealed to prevent impurities from entering; Otherwise, the subsequent wiring becomes inconvenient.
 - After all cables have been connected, the cable inlets, outlets, and joints shall be sealed with fireclay or other suitable material to prevent rodent ingress.



Embed the grounding unit in advance according to the relevant standards of the country or region where the project is located.

3.4.2.3 Fixed installation

- Once the foundation construction is confirmed to meet the requirements and is dry, firm, and flat enough, hoist the battery outdoor cabinet and energy storage converter to the predetermined position.
- Secure the outdoor battery cabinet to the foundation using fastening bolts. After fixing, the U-shaped angle steel should undergo anti-rust treatment, such as spraying anti-rust paint. Additionally, the fire extinguisher should be placed next to the battery cabinet.

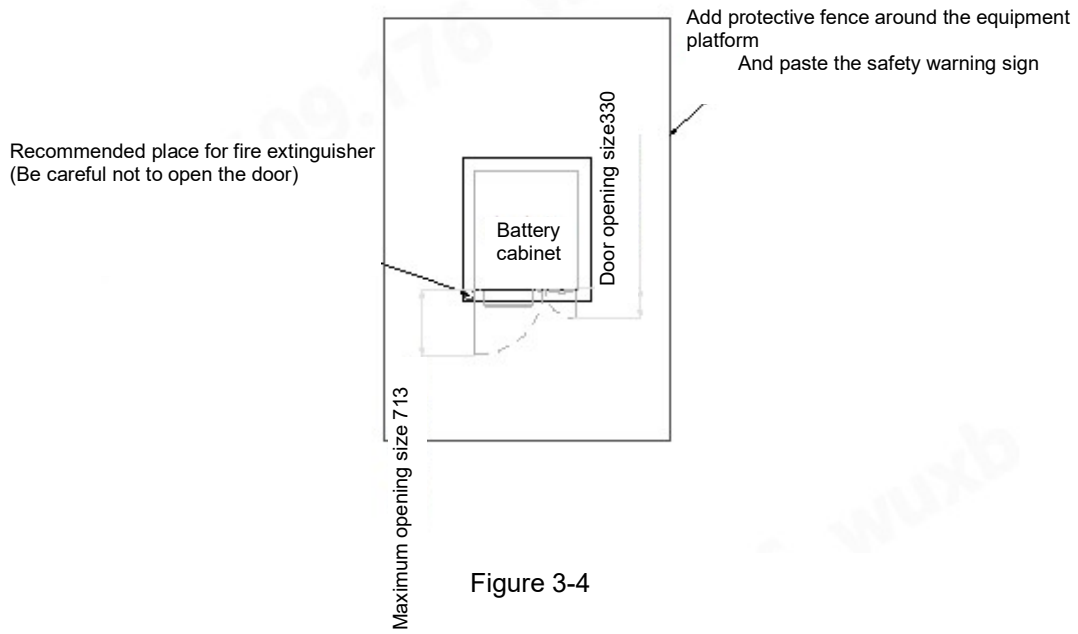

Figure 3-4

3.4.3 Installation instructions for cables between battery modules

3.4.3.1 Battery module

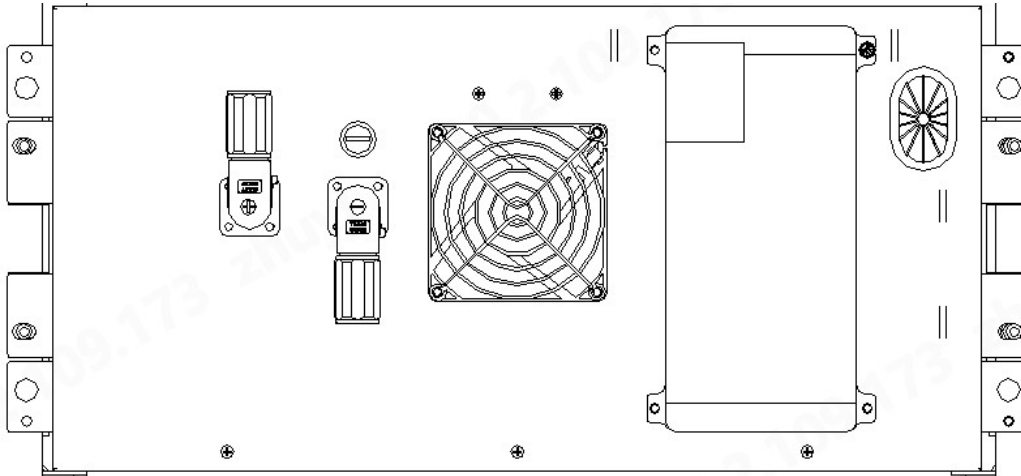





Figure 3-5 Battery module

Description:

1. Negative electrode of the battery module: ;

2. Positive electrode of the battery module: ;

3. DC fan: ;

4. Battery management unit BMU: .

3.4.3.2 Description of power connection of battery module (check the wire mark)

The connection between the battery modules is completed before the battery cabinet is shipped. If the customer needs to maintain the connection between the battery modules, please refer to the following:

Specifications of components:

| Name | Description |
|------|-------------|
|------|-------------|

| | |
|---------------------|---|
| Series quick plug | Quick-connect power cable between battery modules, with |
| "B+, B-" power line | Connecting the wire between module 01 "B-" and the HVB "B-", and connecting the wire between module 06 "B+" and the HVB "B+". |
| BMU acquisition | Cell collection and temperature collection |
| BMU cascade | BMU cascade CAN bus communication line, power supply, |
| BMU fan drive line | BMU fan drive line |

Cable connection between battery modules:

Wear insulating gloves, and install the quick-plug power cable from the battery module in the lower left corner to the top. HVB B- is connected to the sixth PACK negative pole, the sixth PACK positive pole is connected to the fifth PACK negative pole, and so on, and the first PACK positive pole is attached to HVB B+. The power circuit wiring is completed. In addition to the two black and two red fast plugs connected to the HVB at the ends of the fast plug power line, the others have one black and one red plug.

The sequence of the communication cascade line aligns with the PACK power line sequence. The floating end of the communication seat of the fourth (BC70DE2/BC63DE2-AU), fifth (BC89DE2/BC80DE2-AU), and sixth (BC107DE2/BC96DE2-AU) BMU needs to be connected to a terminal resistor.

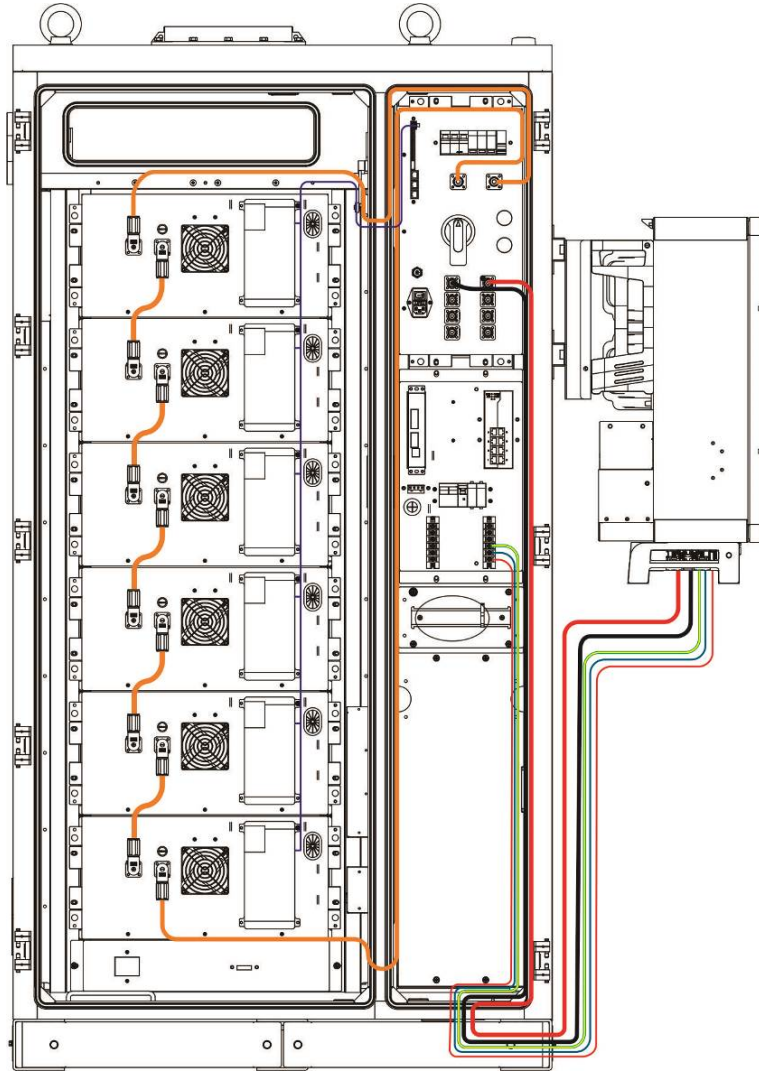

Figure 3-8 BC107DE2/BC96DE2-AU single cabinet communication line and power line diagram

3.5 Electrical connections

⚠ DANGER

Before installation, ensure the circuit breaker switch on the HVB is closed.

3.5.1 AC input connection

Step 1: Make sure the AC Switch is in the "OFF" position.

Note:

- The AC input is 220VAC single-phase, and it is necessary to confirm that it is not energized before wiring.
- The overvoltage class of the AC input is AC OVC II.
- The AC input supplies 220VAC power to the AC/DC power module of the A/C and the HVB.

Step 2: Connect the L/N/PE wires of the AC single-phase 220VAC mains supply line to the corresponding terminals as marked in the figure below, and secure them with bolts (torque ≤ 2 NM).

Note:

- The 3 terminals on the right side of the "INPUT" end are reserved for AC input and can be used for AC power transfer. The 2 groups of terminals at the "OUTPUT" end are used for the internal wiring of the HVB and for supplying AC power to the A/C.
- AC terminal block: UI5.5-5
- AC wiring diameter: $6\text{mm}^2/10\text{AWG}$

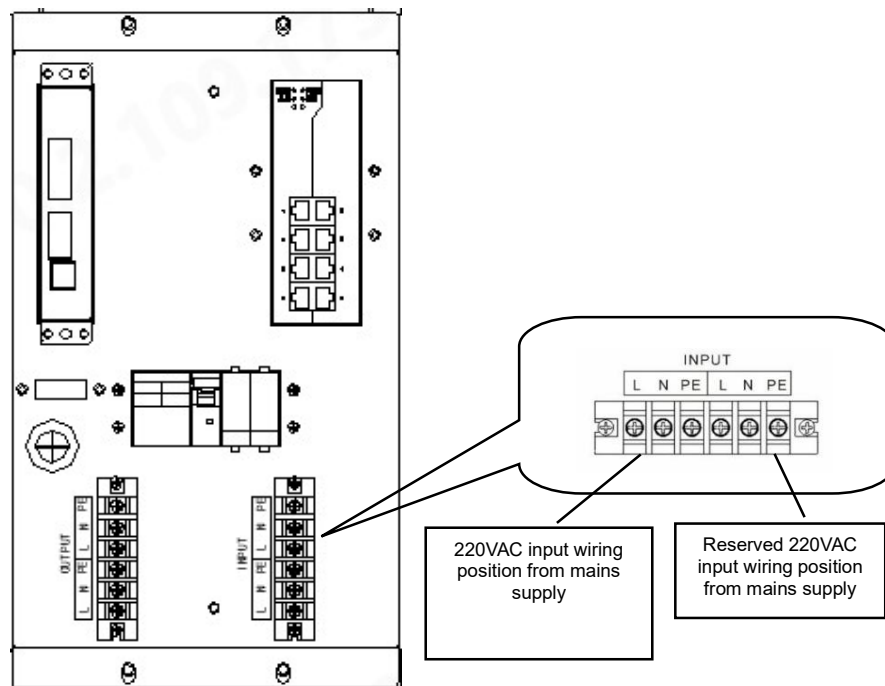

Figure 3-9 Mains supply AC input connections

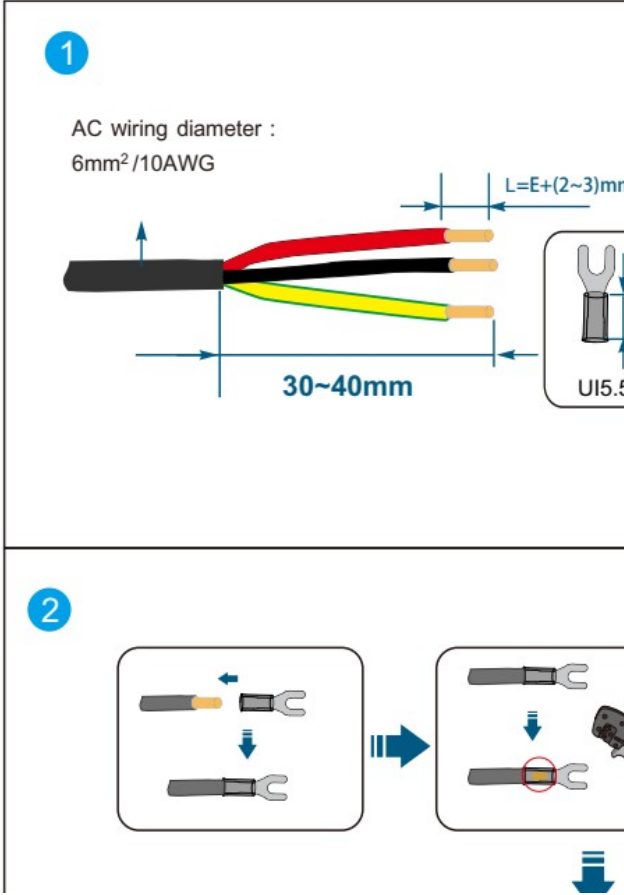

Figure 3-10 AC Terminal Crimping Diagram

3

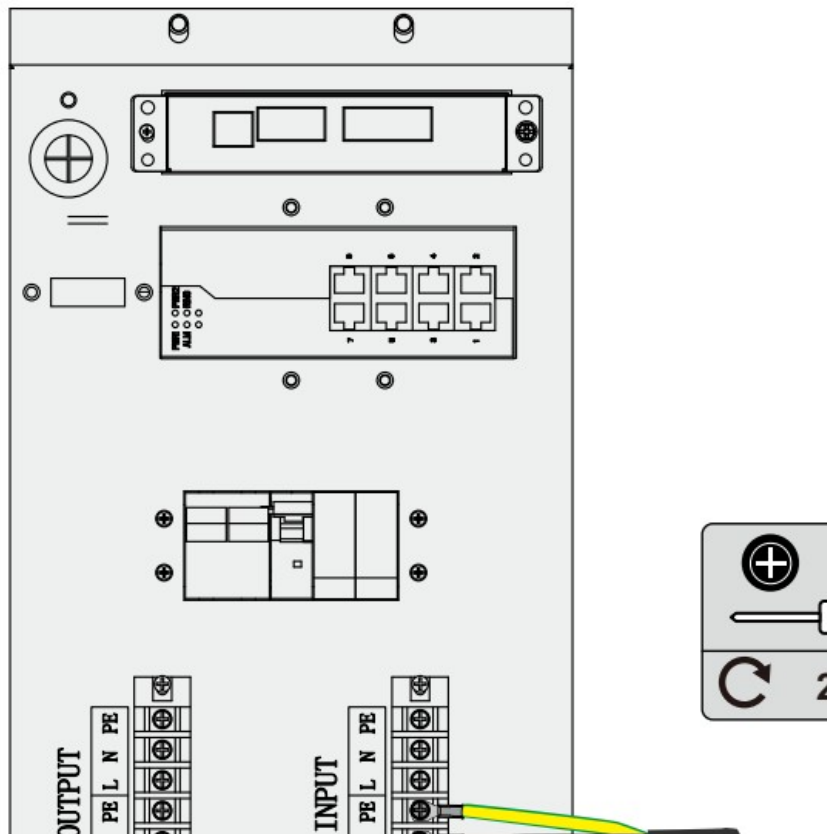

Figure 3-11 AC Distribution Panel Wiring Diagram

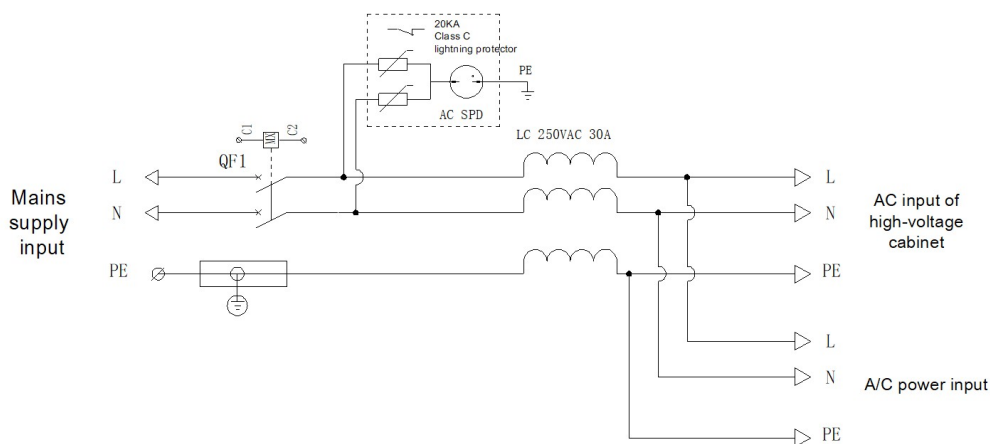

Figure 3-12 Schematic diagram of AC power distribution

The specifications of the A/C are as follows:

| Item | Specification |
|------|---------------|
|------|---------------|

| | |
|------------------------------|---|
| Power supply | 220VAC 50HZ |
| Refrigerating capacity | 3000W |
| Heating capacity | 2000W |
| Method of installation | Door mounted, integrated with the chassis |
| Scope of working environment | -40°C~+55°C |

3.6 Description of communication wiring

1) Connection of network communication interface

The battery cabinet includes a built-in Ethernet lightning arrester, already connected to the network port of the EMS controller. Users only need to connect to the cloud platform or upper monitoring system and directly link to the Ethernet lightning arrester using a standard network cable;

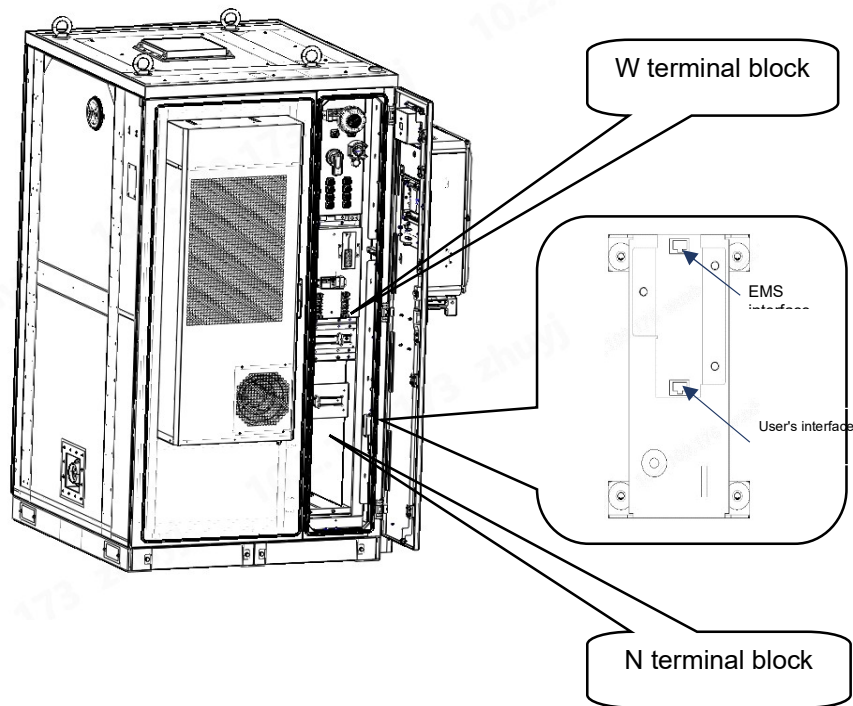

Figure 3-13 Interface diagram of Ethernet lightning arrester and terminal block

2) Wiring terminal block

There are two sets of communication terminal blocks in the battery cabinet. W terminal is the external terminal block used for communication with PCS and external devices, while N terminal is used for internal transfer. The specific definitions are shown in the figure

below.

W terminal block:

| Fire control | | MBMU PCS CAN | | EMS PCS CAN | | EMS PCS 485 | | Electric meter 485 | | 1#reserved 485 client | | 2#reserved 485 PV inverter | | PV Inverter trip | | Mains supply trip | | W1 |
|--------------|-----|--------------|------|-------------|------|-------------|----|--------------------|----|-----------------------|----|----------------------------|----|------------------|-----|-------------------|-----|----|
| NO | COM | CANH | CANL | CANH | CANL | A1 | B1 | A2 | B2 | A3 | B3 | A4 | B4 | NO | COM | NO | COM | W2 |
| 1 | 2 | 3 | 4 | 5 | 6 | 7 | 8 | 9 | 10 | 11 | 12 | 13 | 14 | 15 | 16 | 17 | 18 | |

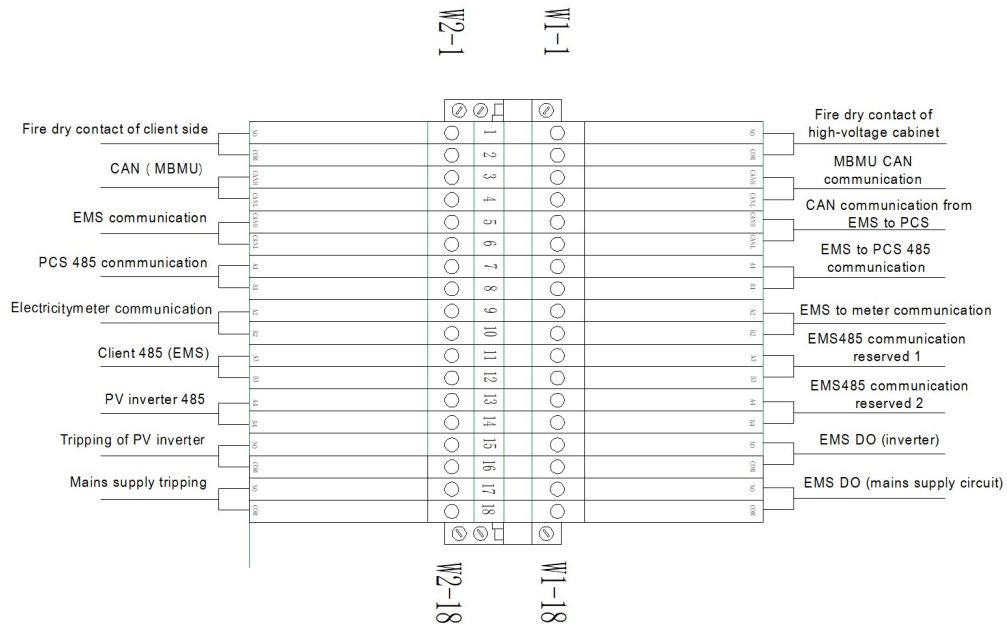

Figure 3-14 Schematic diagram of W terminal connection

N terminal block:

| CO power | | CO feedback | | AC trip | | Valve power control | | Valve power | | | | Valve feedback | | | | Valve control | | | | Fan power | | AVA power control | | AVA power | | Smoke feedback | | EPO feedback | | N1 |
|----------|-----|-------------|----|---------|-----|---------------------|--------------|--------------|-------------|-------------|-------------|----------------|-------------|-------------|-----------------|-----------------|-----------------|-----------------|---------|-----------|----|-------------------|---------|-----------|-----------|----------------|---------|--------------|--|----|
| 24V+ | GND | DI | DI | 24V+ | GND | 1 | Valve-1 24V+ | Valve-2 24V+ | Valve-1 GND | Valve-2 GND | Valve-1 DI+ | Valve-2 DI+ | Valve-1 DI- | Valve-2 DI- | Valve-1 control | Valve-2 control | Valve-1 control | Valve-2 control | FAN GND | FAN 24V+ | 1 | AVA 24V+ | AVA GND | Smoke DI+ | Smoke DI- | EPO DI+ | EPI DI- | N2 | | |
| 1 | 2 | 3 | 4 | 5 | 6 | 7 | 8 | 9 | 10 | 11 | 12 | 13 | 14 | 15 | 16 | 17 | 18 | 19 | 20 | 21 | 22 | 23 | 24 | 25 | 26 | 27 | | | | |

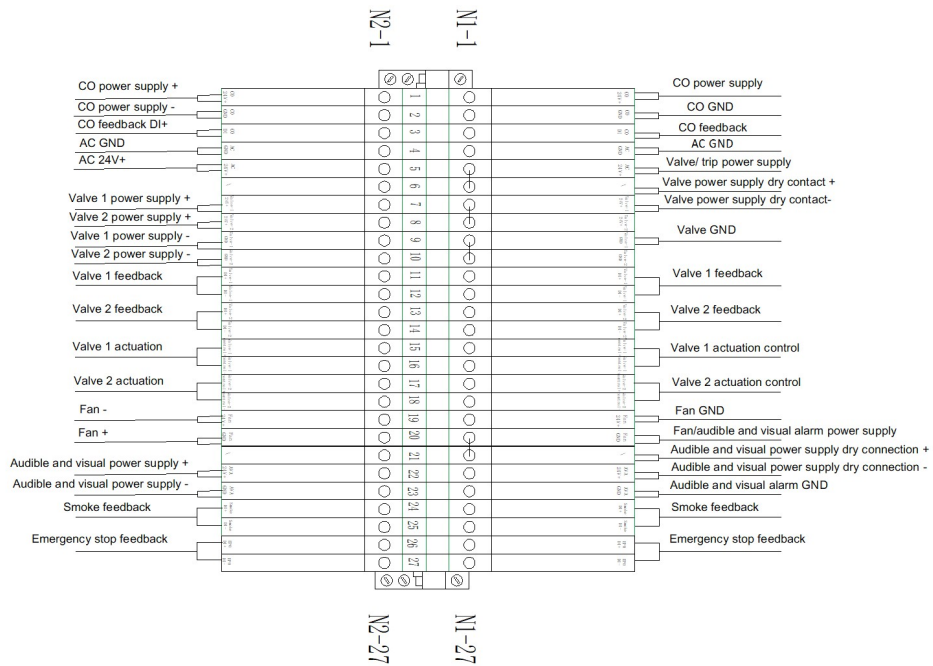
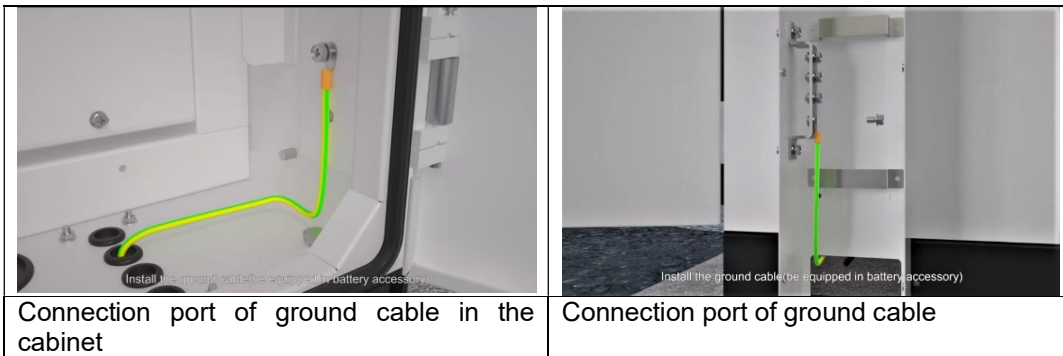
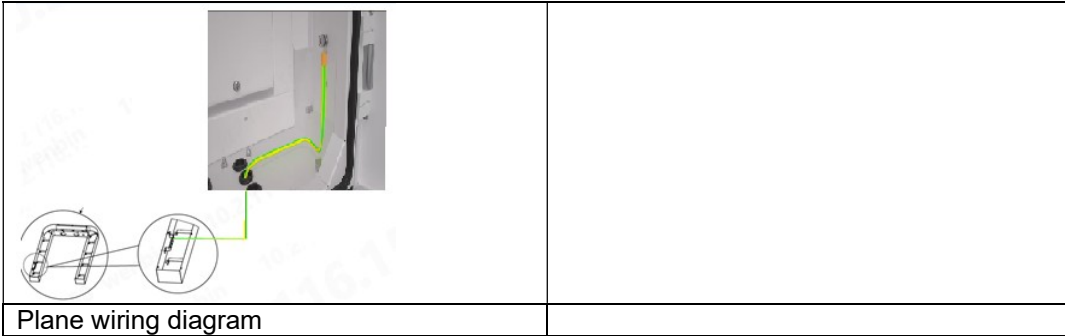

Figure 3-15 Schematic diagram of N terminal connection

3.7 Install Ground cable for the battery cabinet





EARTH FAULT INTRODUCTION

Earth faults caused by insulation failure or accidental contact between live parts and ground that creates a low-resistance path for current to flow to earth, represent significant risks that require proper understanding and protective measures to mitigate their potentially dangerous effects.

EARTH FAULT ALARM

In the event of an earth fault, the inverter will display a fault code and push an alarm notification via the KEMS.

3.8 Installing DC Cables between PCS and ESS Cabinet

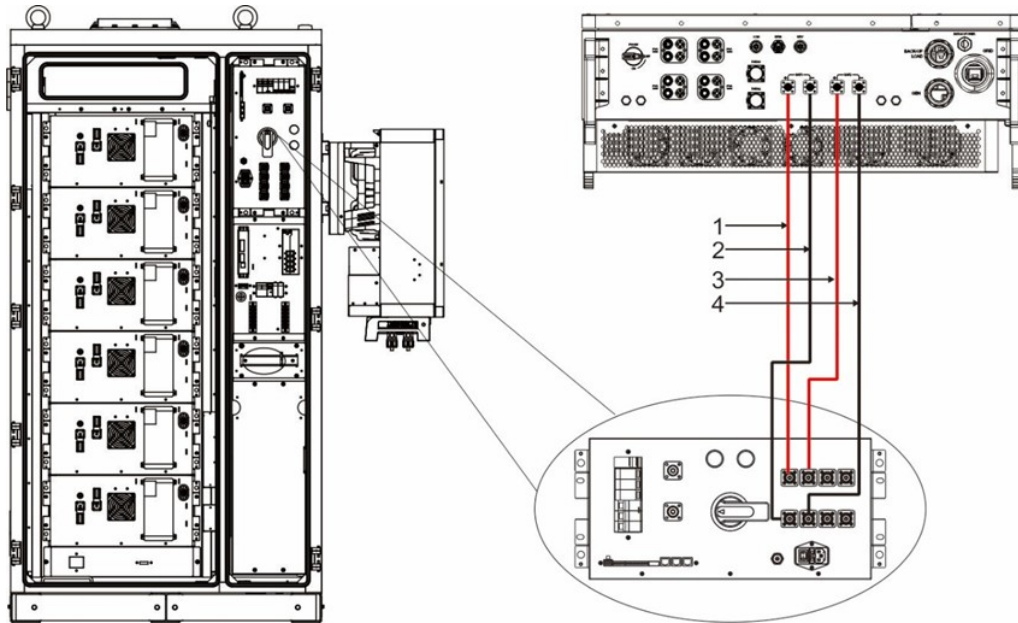

| NO | FROM | | TO | |
|----|----------|-------|----------|----|
| 1 | KAC50DP2 | BAT1+ | BC107DE2 | P+ |
| 2 | | BAT1- | | P- |
| 3 | | BAT2+ | | P+ |
| 4 | | BAT2- | | P- |

3.9 Installing Communication Cables between PCS and ESS Cabinet

When there are 2 ESS cabinets connected with 1 PCS, only the leader ESS cabinet communicates with the PCS.

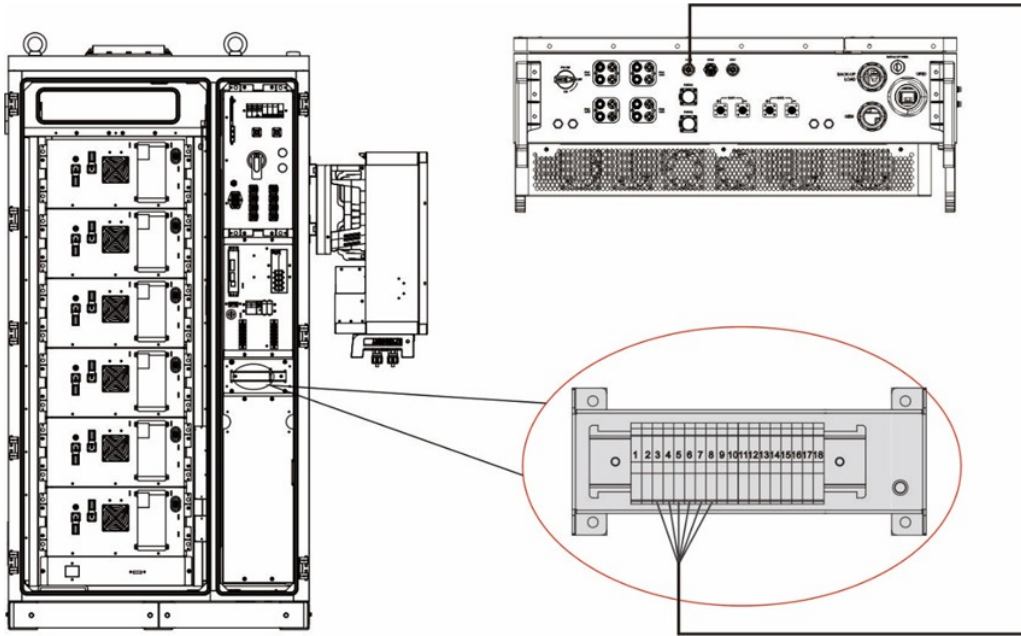

| FROM | | TO | | |
|----------|-----|------------------------------|----------------|------|
| KAC50DP2 | COM | BC107DE2 W terminal block | PCS-MBMU CAN_H | Pin3 |
| | | | PCS-MBMU CAN_L | Pin4 |
| | | | PCS-EMS CAN_H | Pin5 |
| | | | PCS-EMS CAN_L | Pin6 |
| | | | PCS-EMS 485_A | Pin7 |
| | | | PCS-EMS 485_B | Pin8 |

3.10 Installing an awning (Optional)

Given that the ESS has an IP rating of IP54, installing a canopy provides physical protection and environmental adaptability for the outdoor energy storage battery cabinets, ensuring the safe, stable, and efficient operation of the energy storage system.

Canopy Installation Recommendations:

- The canopy should extend 1.2 meters beyond the front of the energy storage cabinet;
- The canopy should extend 1 meter beyond each side of the energy storage cabinet;
- The canopy should be positioned 0.5 meters above the top of the energy storage cabinet.

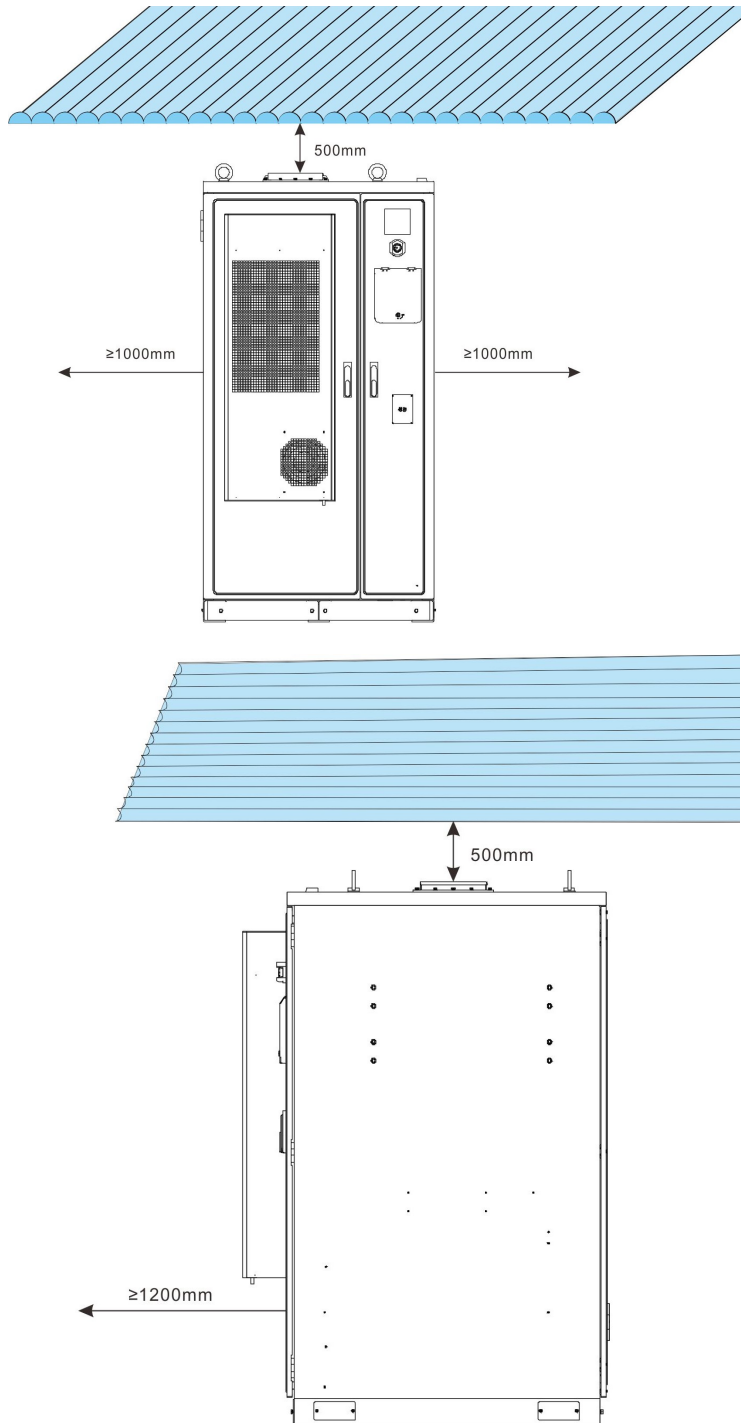

4 Operation instructions

4.1 Inspection after installation

⚠ DANGER

- Personnel responsible for installing and maintaining equipment must first undergo rigorous training, comprehend various safety precautions, and master the correct operating methods.
- Only qualified professionals or trained personnel may install, operate, and maintain the equipment.

Inspection steps:

Step 1 Check the fixing of the module box

- Verify that the battery module, HVB, and battery cabinet are securely fixed.

Step 2 Check the power harness

- Check whether the power lines between battery modules and between battery modules and the HVB are firmly connected;
- Check whether the P+/P- quick-plug power line is connected in reverse and if the plug and socket are completely locked;
- Check whether the 220VAC mains supply input line is connected correctly, and ensure that the fastening bolts are not missing, loose, or improperly torqued.

Step 3 Check the communication harness

- Check if the communication power supply harnesses are loose or missing between battery modules, between battery modules and HVBs, between HVBs, between HVBs and MBMU modules, and between EMS units.
- Verify if the power supply communication harness between the PCS CAN communication harness and the MBMU module is loose or missing.
- Check whether the CAN communication harness of the HVB outside the cabinet is correctly connected to the interface of the HVB inside the cabinet, and ensure it is neither loose nor missing.

Step 4: Check the power supply, drive, and communication harnesses of the fire start box.

- Check the power supply of the fire start box. The power indicator light should be on or flashing. If the power indicator does not light up, please contact Shenzhen KSTAR New Energy Co., Ltd.
- Check if the fire start, power supply, feedback, and other wiring harnesses are loose or missing. If you find any abnormality that cannot be resolved, please contact the customer service center of Shenzhen KSTAR New Energy Co., Ltd.

4.2 Inspection of operating environment

Check the battery cabinet's operating temperature: -30°C to 50°C.

Check the operating humidity of the battery cabinet: 5%~95%, no condensation.

4.3 Power-on operation

4.3.1 Prerequisite

- Before powering on, ensure that all post-installation checks have been completed.
- Before powering on, measure the input voltage of the battery cabinet to ensure it is normal (between 342 and 432 VDC).
- Before turning on the power, ensure all switches are in the off position.

4.3.2 Operation steps

- If there is a 220VAC AC mains supply input

Step 1: Turn the AC switch to the "ON" position to supply power to the 220VAC port of the battery cabinet.

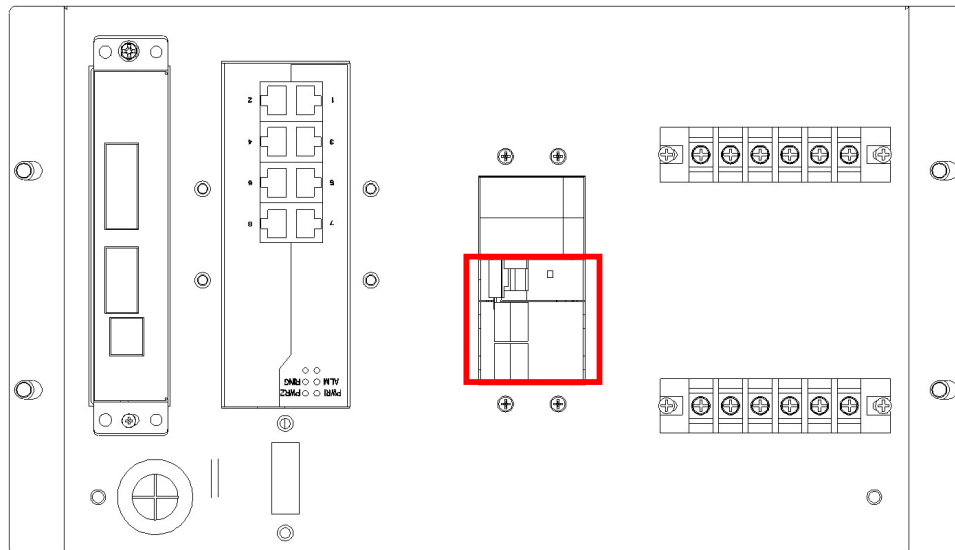

Step 2: Close the rocker switch located next to the three-pin plug on the HVB.

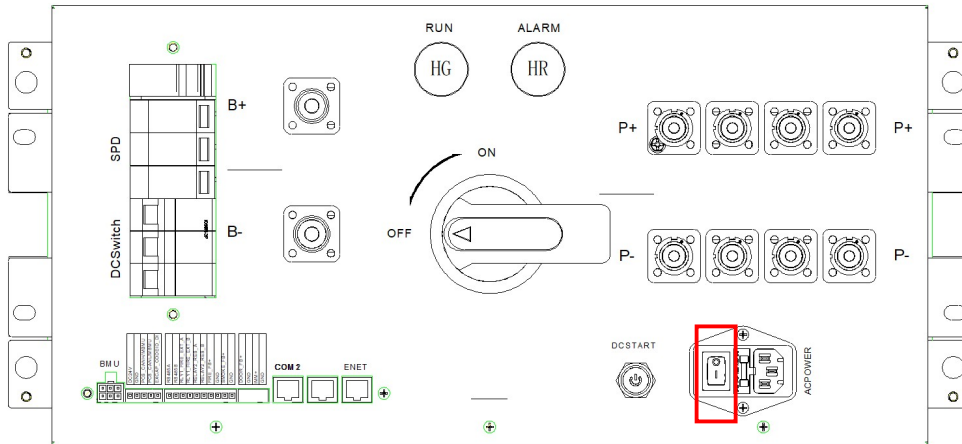

Step 3: Turn the DC Switch to "ON" .

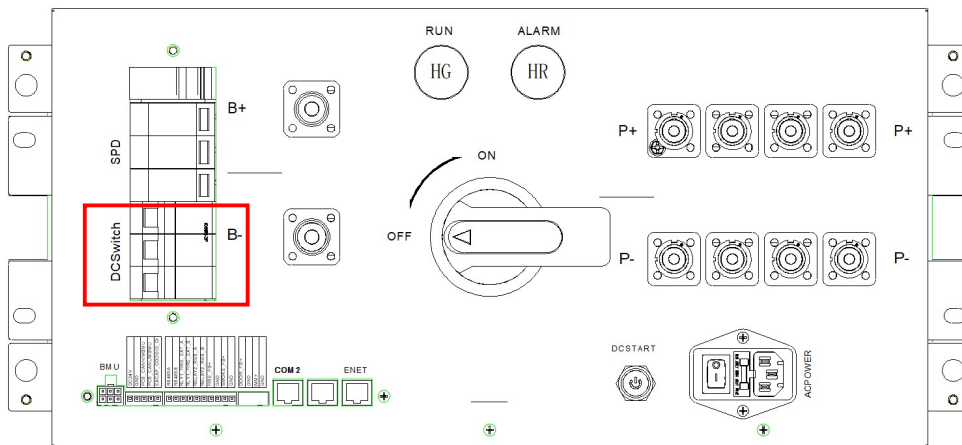

Step 4: Move the DC circuit breaker switch handle of the HVB in the battery cabinet to the "ON" position.

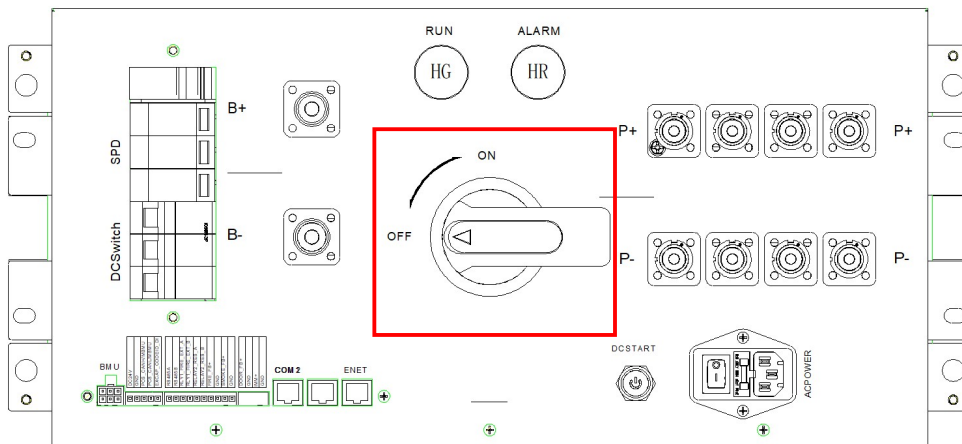

Step 5: Confirm that the indicator's green light remains illuminated.

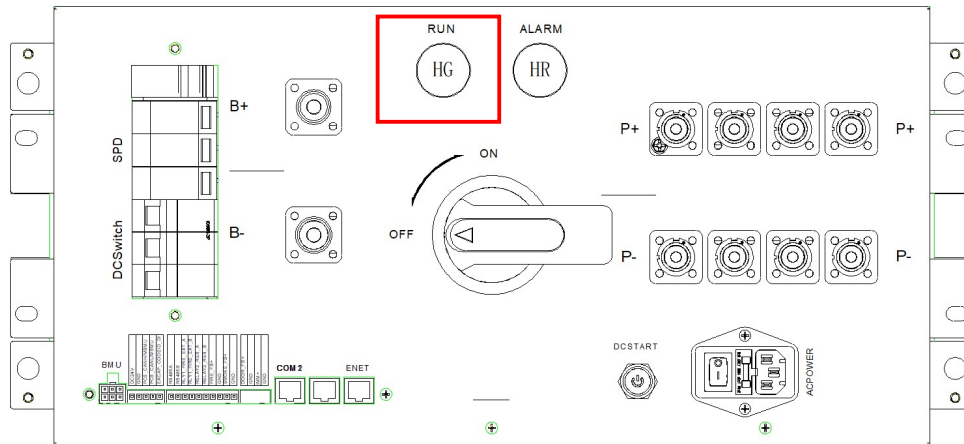

Step 6: Confirm if the A/C is running.

Step 7: Check the EMS display screen on the front door of the battery cabinet to see if the parameters are normal or if there is any fault.

----End

- If there is no 220VAC AC mains supply input

Step 1: Turn the DC Switch to "ON" .

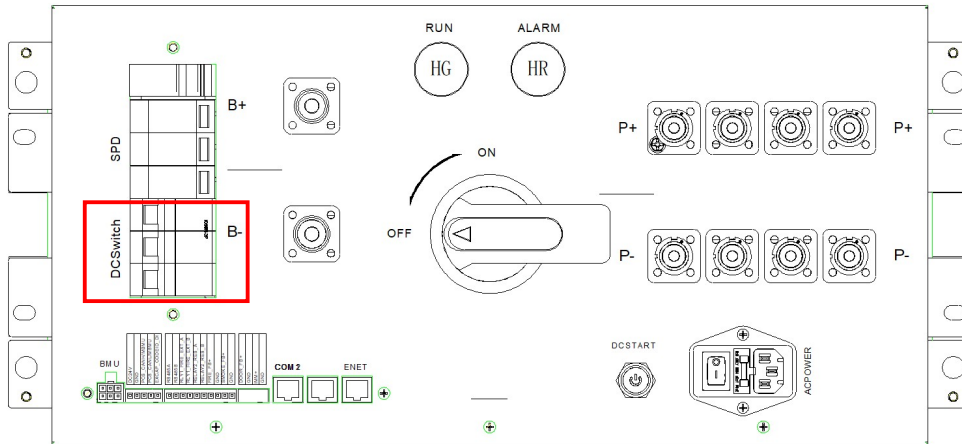

Step 2: Turn the switch handle of the HVB located in the battery cabinet to the "ON" position.

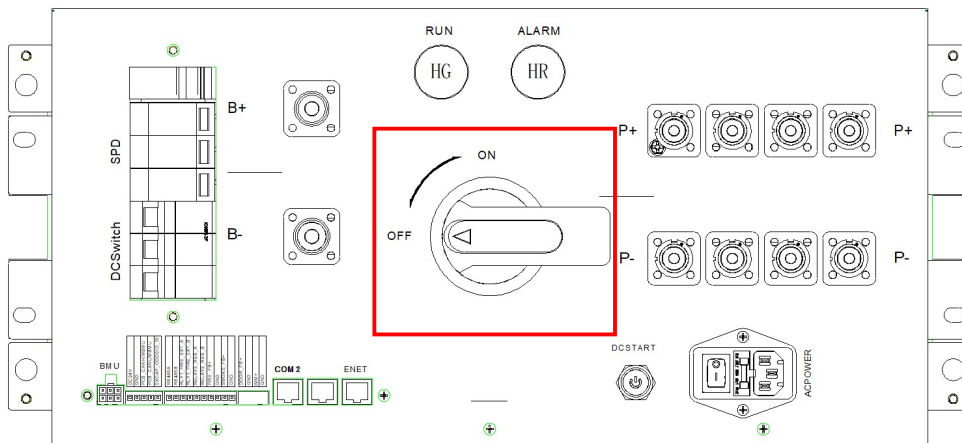

Step 3: Press the "DC START" button on the HVB in the battery cabinet. After starting, the indicator light will turn on. Hold the "DC START" button for 3-6 seconds. When you hear the crisp closing sound of the high-voltage contactor in the HVB, release the button to achieve DC black start.

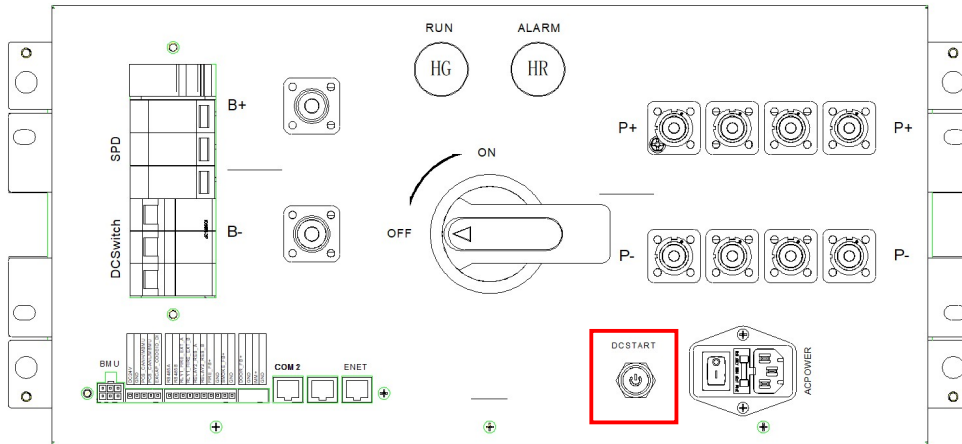

Step 4: Ensure the indicator's green light remains illuminated at all times.

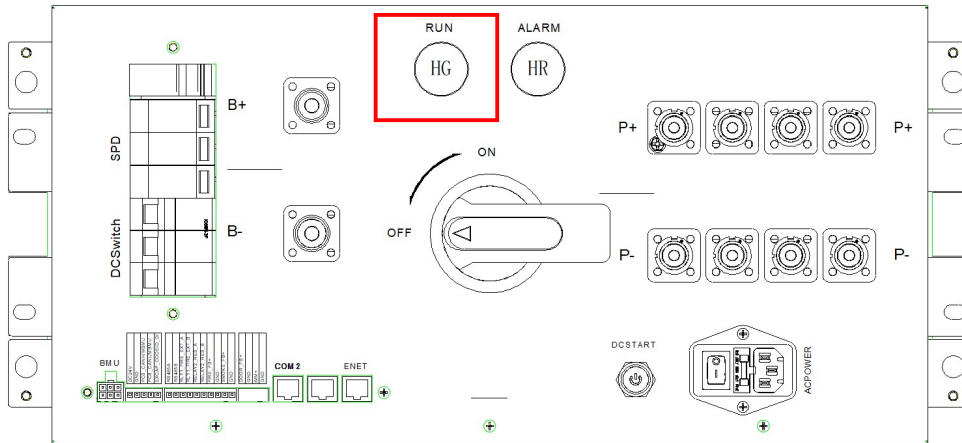

Step 5 (Optional: Power supply switching can be achieved when mains power is available)

Turn the AC Switch to "ON" .

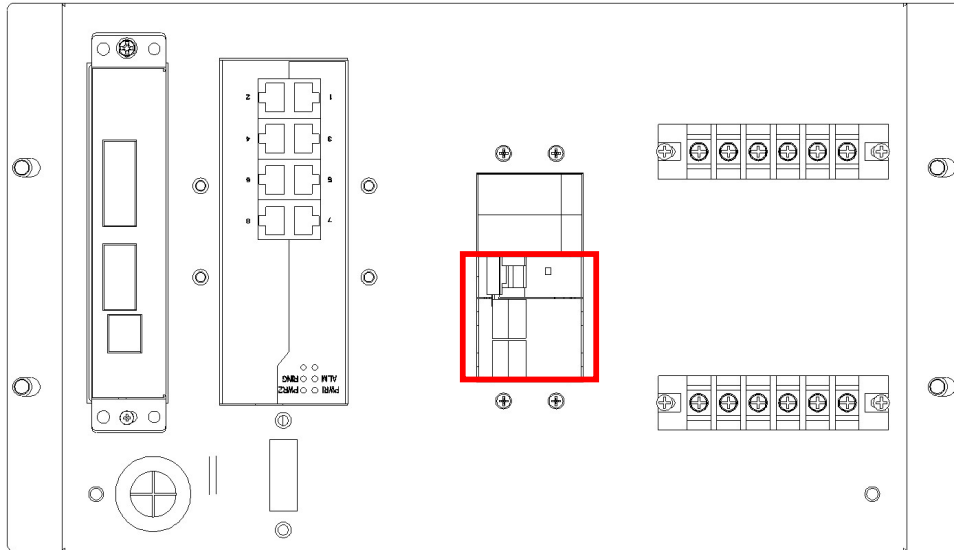

Step 6 (Optional: Power supply switching can be achieved when mains power is available)

Turn off the "AC POWER" rocker switch on the HVB.

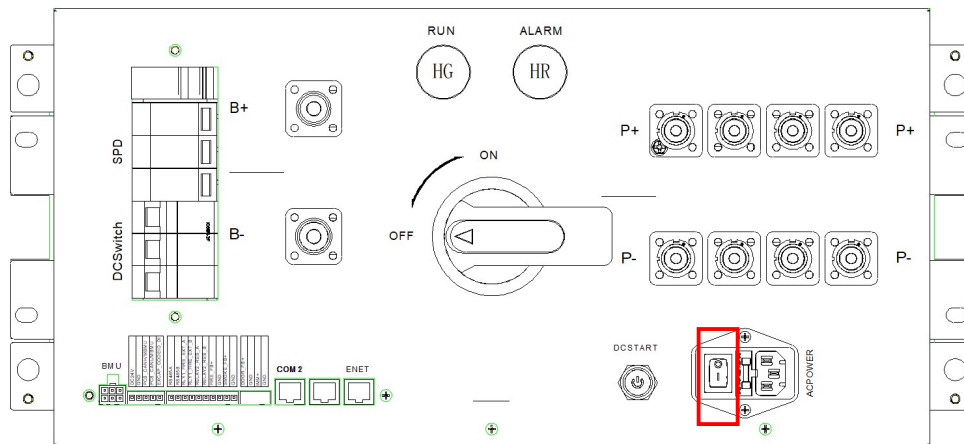

Step 7: Check the EMS display screen on the front door of the battery cabinet to see if the parameters are normal or if there is any fault.

----End

After successfully completing the self-inspection of all clusters in the energy storage battery cabinet, close the cluster DC contactor in the system using the touch screen or other system control tools. After completing the DC contactor closing operation, it is necessary to confirm if there is a system fault. Once all battery clusters in the system are online, the system's high-voltage power-on operation is complete.

4.4 Power-off operation

4.4.1 Power-off steps

Step 1: Use the EMS screen to perform one-click shutdown of the PCS.

Tap "Settings -> Device Control -> PCS" to switch the PCS on or off.

Note: A password dialog box appears. The password is "000000".

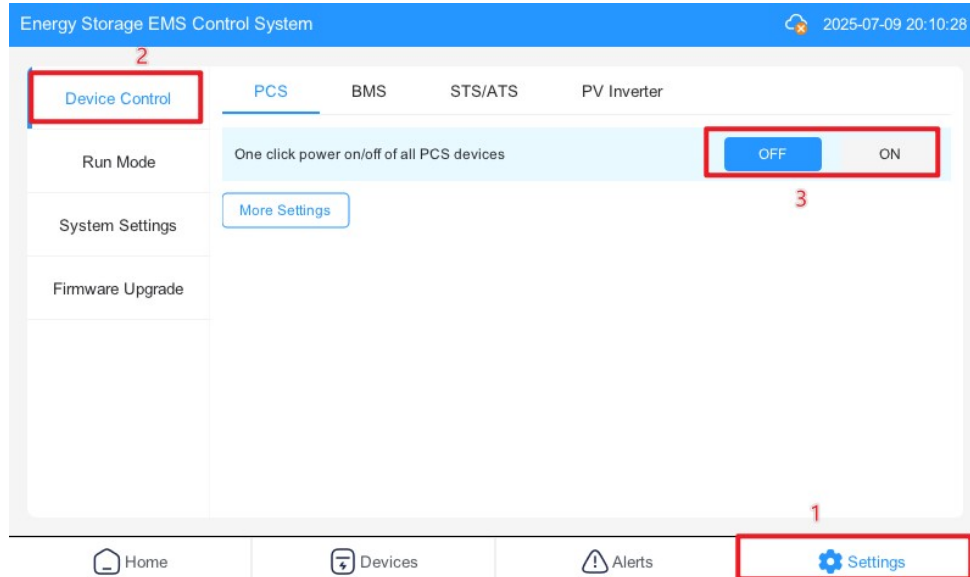

Step 2: Turn the handle of the HVB DC molded-case circuit breaker to the "OFF" position.

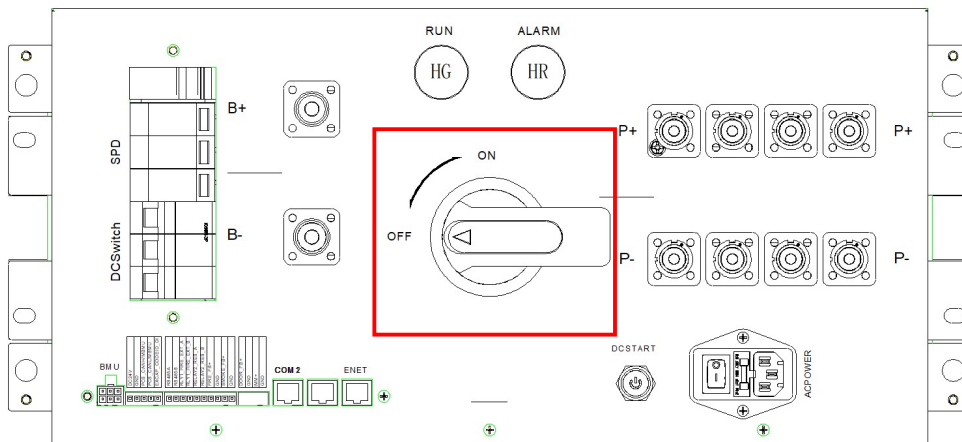

Step 3: Turn the DC SWITCH on the HVB to the "OFF" position.

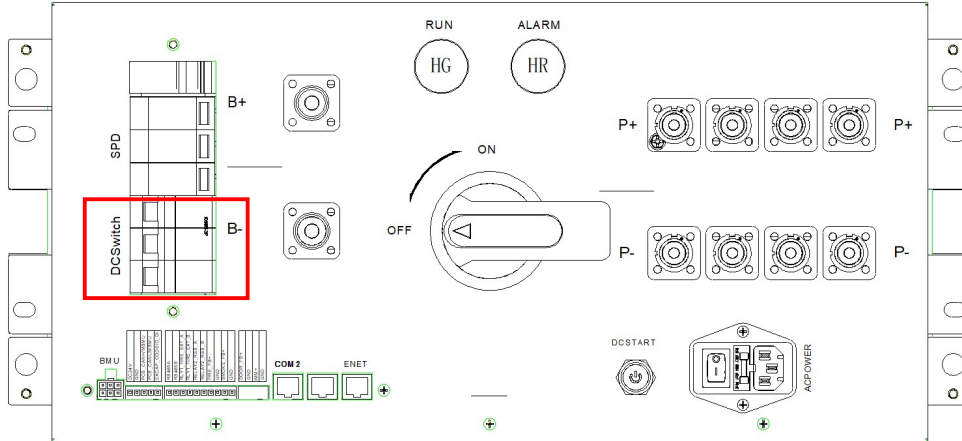

Step 4: Turn off the "AC POWER" rocker switch on the HVB.

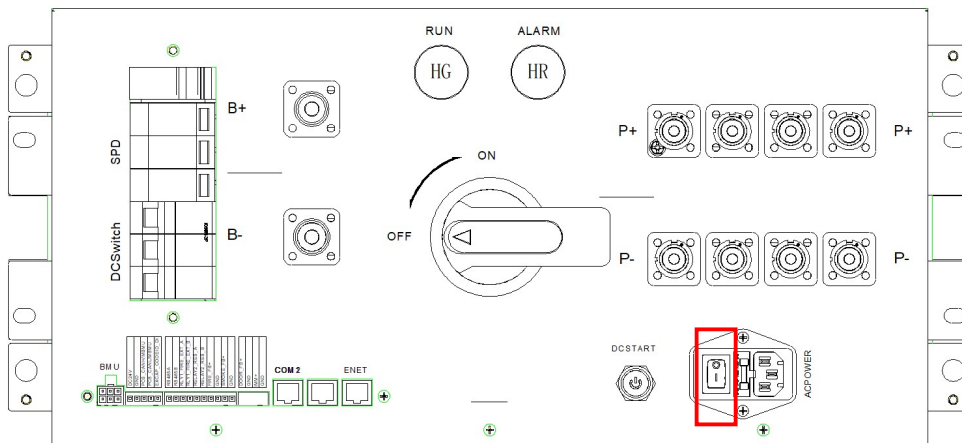

Step 5: Turn the AC Switch on the AC distribution box to the "OFF" position.

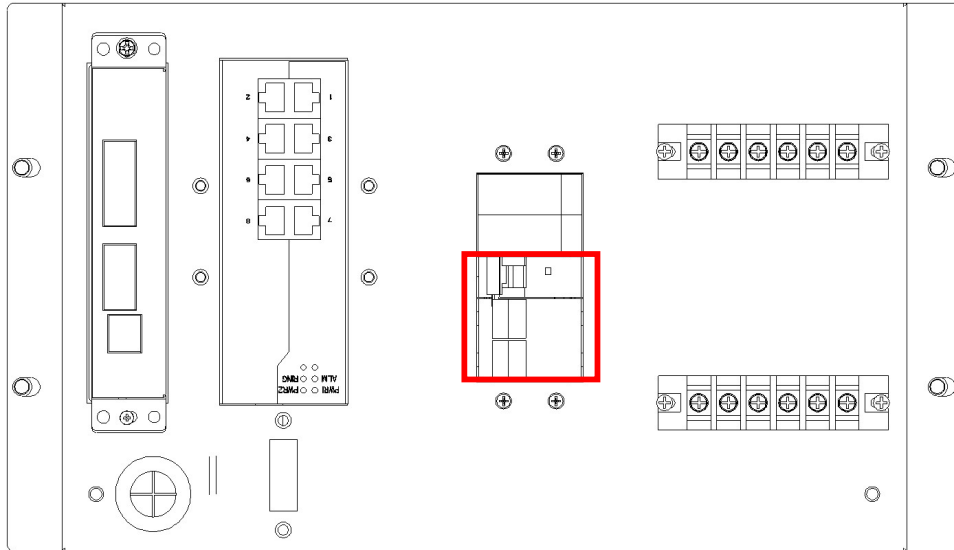

---End

4.4.2 Emergency power-off



Figure 4-1 Emergency stop switch button

Press the emergency stop switch. The HVB release will be disconnected, the AC idle

circuit will trip, and the battery system will be de-energized.

4.5 Commissioning of battery cabinet

The battery cabinet interacts with the outside by exchanging energy through the energy storage converter. Precautions for commissioning are as follows:

Capacity calibration: ensure the battery can complete a normal charge and discharge cycle. If it is necessary to modify the rated capacity, deep charging and discharging should be carried out during commissioning and joint commissioning. It is recommended to calibrate the capacity once during the test run, with a charge and discharge depth (DOD) of 100%, and to test according to the product's rated power. The default process includes three steps: "venting + standing (2h) + full," which are described as follows:

- Discharge: The battery cluster is discharged until the SOC reaches 0%.
- Standing: Standing for more than 2 hours (for SOC correction). During standing, there must be no charging or discharging current, and no auxiliary power supply is required in the HVB.
- Fully charged: Once the resting period is complete, conduct a full charge test by charging to SOC = 100%.
- If not used for a long time (6 months), the energy storage battery should be recharged to over 50% SOC promptly. Considering that the SOC may have accumulated errors due to long-term shallow charging and discharging, it is recommended to shut down the SOC after a full charge.

Operation stability: Power circuits, communications, data collection, and other components should be operated at rated power during debugging if conditions permit. It is used to determine whether there are any abnormalities in each link of system installation, especially in cases of over-temperature, over-current, over-voltage, and over-discharge. These abnormalities should be handled promptly to avoid potential safety hazards.

4.6 SOC calibration operation

Step 1:

Confirm that the screen program used is a seven-in-one program, and the version number is higher than V000B010D000.

Step 2:

After the system configures the boot interface and completes system debugging, click "Setting," followed by "Equipment Control," "BMS," and "SOC Calibration" in sequence. Enter the SOC calibration interface.

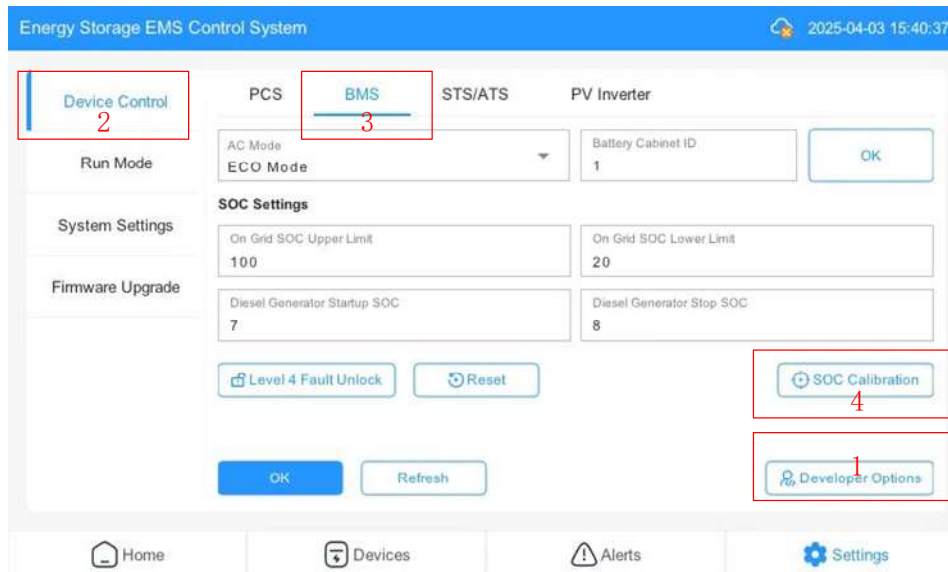

Step 3:

Customers are advised to fill it up at the peak of electricity consumption.

5 Routine maintenance

NOTICE

Installation and servicing work inside the battery cabinet must be performed using insulated tools by personnel who have received relevant training. Devices enclosed in protective covers that require tools for opening are not user-serviceable. If maintenance is needed, please contact Shenzhen KSTAR New Energy Co., Ltd. for more information.

- The battery cabinet should be maintained regularly according to the following requirements. Failure to do so will affect its normal operation and reduce its service life.

5.1 Maintenance

The battery system needs to be inspected monthly to check for any abnormal alarms and to observe the current state of the electric cabinet.

- Observe the EMS interface to check for any current alarm information from the BMS. If an alarm is present, review all recent operations to determine if they are reasonable.

- Review the historical data from this period to determine if there is a significant fault. Mainly observe the battery history information of the entire cluster on the EMS interface and check for false alarms or irreversible alarms. Refer to Table 5-1 for detailed alarm types.
- Conduct regular patrol inspections and check the fire power indicator. When the fire extinguisher's power supply battery is low, it should be replaced promptly. Avoid affecting the discharge of consumer-grade fire extinguishers.
- Dirty and blocked A/C condenser is the main reason for the decrease of cooling capacity. In order to improve the work of A/C, it is recommended to clean the condenser every 6 months.

Table 5-1 Fault alarm query table

| Fault content | Description | Common exception reference handling methods (non-exhaustive) |
|------------------------------|--|--|
| Access control alarm | Battery cabinet door status detection, alarm will be given if the door is opened for more than 2 minutes. If the alarm still occurs with the door closed, investigate the cause further. | <ol style="list-style-type: none"> 1. Check if the mechanical travel switch of the access control is loose or abnormal. 2. Whether the normally open and normally closed wiring is correct 3. The voltage at the interface of the HVB panel seat is used to determine if it has been mistakenly triggered. |
| Water immersion alarm | Check whether there are false alarms, and check whether the cabinet is immersed in water | <ol style="list-style-type: none"> 1. If soaking, drain the water first. When the water level evaporates dry, the alarm resumes. 2. If there is a false alarm, check the harness. 3. Measure the voltage at the interface of the HVB panel for further assessment. |
| Fire alarm | Check for false alarms; Detect whether the fire is erupted | <ol style="list-style-type: none"> 1. If a fire erupts, first observe the situation in the cabinet to check for any traces of fire. If a fire is present, the cabinet is essentially scrapped. If there is no fire and smoke, first check the integrity of the cabinet. If it is intact, clean the aerosol in the cabinet first. The fire extinguishers that have been sprayed need to be replaced. 2. If it is a false alarm, check for any abnormalities in the harness. After disconnecting the external harness, measure whether the interface voltage of the HVB panel is normal. |
| Contactors fault or adhesion | Adhesion or failure to close | Observe whether the drive and feedback of the contactor are consistent with each other with the |

| | | |
|--|--|---|
| | | upper computer. If not, the contactor is faulty. That is, there is drive, and the auxiliary contact is disconnected; No drive, auxiliary contact closed. |
| Cell overvoltage level 4 | Cell up to 3.8V, SOC100% | The upper computer is required to contact the locking state, and the cell overvoltage parameter value is appropriately adjusted for forced discharge. After recovery, the cell overvoltage parameter value is reduced. Find out the cause of overvoltage level 4. |
| Cell overvoltage level 1 level 2 level 3 | Cell voltage between 3.6-3.8V, SOC 100% | It can be restored by the system forced discharge function. |
| Cell undervoltage level 4 | Maximum cell is less than 2.5V | The cell with a single voltage lower than 2.0V shall be scrapped; For level 4 undervoltage higher than 2.0V, the locking state must be released through the upper computer and the parameter value must be modified; Restore by forced charging of system. Restore the parameter values after the alarm has been restored. Check the cause of undervoltage. |
| Cell undervoltage level 1 level 2 level 3 | Cell 2.5-3.0V | It can be restored through the system strong charge function |
| Cell differential pressure alarm in cluster | Differential pressure greater than 500mV | <ol style="list-style-type: none"> 1. When running near full load, it is common for the platform voltage to be exceeded, which is a normal phenomenon. 2. With the use of electric cabinets gradually aging, the internal resistance of cells increases, making it more likely to appear under large current charge. This is a normal phenomenon. As long as the cell voltage, temperature, and current are within the normal range, the system will function properly. |
| Large cell voltage variation in a battery system in a static state | Voltage exceeds 10mV when stationary. | <ol style="list-style-type: none"> 1. Check whether the wiring is loose 2. Replace the corresponding BMU |
| Overtemperature alarm for cell | Cell temperature $\geq 45^{\circ}\text{C}$. | <ol style="list-style-type: none"> 1. Whether the A/C cools normally 2. Whether the ambient temperature is too high 3. Whether BMU temperature sampling is faulty 4. Whether NTC is faulty |
| Charging temperature is too low | Cell temperature $\leq 0^{\circ}\text{C}$ | <ol style="list-style-type: none"> 1. Check whether the A/C heats normally 2. Check whether the ambient temperature is too low |

| | | |
|--|--|--|
| | | <ul style="list-style-type: none"> 3. Whether NTC acquisition is normal 4. Whether the BMU acquisition is normal 5. Whether the wiring is loose |
| The discharge temperature is too low | Cell temperature $\leq -25^{\circ}\text{C}$ | <ul style="list-style-type: none"> 1. Check whether the A/C heats normally 2. Check whether the ambient temperature is too low 3. Whether NTC acquisition is normal 4. Whether the BMU acquisition is normal 5. Whether the wiring is loose |
| PCS-BMS communication fault | Abnormal CAN communication | <ul style="list-style-type: none"> 1. CAN of PCS or BMS works abnormally; PCS not started, etc. 2. Check whether the harness is poorly connected, incorrectly connected, or not connected at all. |
| Parallel communication failure | CAN communication of SBMU-MBMU | <ul style="list-style-type: none"> 1. Lack of terminal resistance or excessive terminal resistance 2. Check the harness for signs of poor contact or any abnormalities. 3. The board works abnormally, etc. |
| A/C communication fault | 485 communication | <ul style="list-style-type: none"> 1. Check the harness 2. The A/C is not turned on 3. The board works abnormally 4. A/C failure, etc. |
| BMS communication failure | BMS-EMS Ethernet communication | <ul style="list-style-type: none"> 1. Reconnecting after communication interruption 2. Poor contact 3. PHY chip failure, etc. |
| Insulation fault | Insulation resistance $<1\text{K}\Omega/\text{V}$ | <ul style="list-style-type: none"> 1. There is an electrical leakage, with the sampling line or high-voltage side harness directly or indirectly contacting the chassis. 2. The board works abnormally. |
| Pre-charge failure | Pre-charge failed for three times in total | <ul style="list-style-type: none"> 1. Load capacitance is too large 2. Load short circuit 3. Damage of power device of pre-charging circuit, etc. 4. The board works abnormally |
| SPD lightning protection failure | Alarm triggered by lightning arrester | <ul style="list-style-type: none"> 1. Reverse connection of normally open and normally closed lightning arrester 2. Damage of lightning arrester 3. The board works abnormally |
| Positive and negative pole temperature fault | Temperature of pole | <ul style="list-style-type: none"> 1. Poor contact of pole 2. Check whether the board works normally 3. Poor wire harness contact, etc. |
| Excessive temperature | Temperature difference between cells $\geq 10^{\circ}\text{C}$ | <ul style="list-style-type: none"> 1. Verify if the A/C is functioning properly and ensure that the |

| | | |
|--------------------|--|--|
| difference of cell | | cooling, heating, and air supply are operating normally in their respective states. 2. Check whether the board sampling is abnormal |
|--------------------|--|--|

Table 5-2 Alarm Code

| Alarm | Alarm Code |
|--|------------|
| Communication interruption between EMS and BMS | ID000000 |
| Internal communication fault | ID000001 |
| Pre-charge failure | ID000002 |
| Display screen communication fault / Reserved | ID000003 |
| PCS communication fault | ID000004 |
| Level-4 Alarm: cell voltage too high (Cluster 1 warning) | ID000005 |
| Level-4 Alarm: cell Total voltage too low | ID000006 |
| Level-4 Alarm: Total voltage too high | ID000007 |
| Level-4 Alarm: Total voltage too low | ID000008 |
| Level-4 Alarm: Battery discharge overtemperature | ID000009 |
| Level-4 Alarm: Battery charging overtemperature | ID000010 |
| Level-4 Alarm: Main positive relay fault | ID000011 |
| Level-4 Alarm: Main negative relay fault | ID000012 |
| Level-4 Alarm: Fire protection fault | ID000013 |
| Level-4 Alarm: Water Immersion Fault | ID000014 |
| Level-3 Alarm: cell voltage too high | ID000015 |
| Level-3 Alarm: cell Total voltage too low | ID000016 |
| Level-3 Alarm: Single Cell voltage imbalance too large (Level-1) | ID000017 |
| Level-3 Alarm: Total voltage too high | ID000018 |
| Level-3 Alarm: Total voltage too low | ID000019 |
| Level-3 Alarm: Battery discharge overtemperature | ID000020 |
| Level-3 Alarm: Battery discharge undertemperature | ID000021 |
| Level-3 Alarm: Battery charging overtemperature | ID000022 |
| Level-3 Alarm: Battery Charging undertemperature | ID000023 |
| Level-3 Alarm: Charging Current Too High | ID000024 |
| Level-3 Alarm: Discharging Current Too High | ID000025 |
| Level-3 Alarm: Insulation Fault | ID000026 |
| Level-3 Alarm: Pre-charging Fault | ID000027 |
| Level-3 Alarm: AFE Chip Fault | ID000028 |

| | |
|---|----------|
| Level-3 Alarm: Balancing Circuit Fault | ID000029 |
| Level-3 Alarm: Current Sensor Fault | ID000030 |
| Level-3 Alarm: Terminal Pole overtemperature | ID000031 |
| Level-2 Alarm: Cell voltage too high | ID000032 |
| Level-2 Alarm: Cell Total voltage too low | ID000033 |
| Level-2 Alarm: Total voltage too high | ID000034 |
| Level-2 Alarm: Total voltage too low | ID000035 |
| Level-2 Alarm: Battery Discharging overtemperature | ID000036 |
| Level-2 Alarm: Battery Discharging undertemperature | ID000037 |
| Level-2 Alarm: Battery Charging overtemperature | ID000038 |
| Level-2 Alarm: Battery Charging undertemperature | ID000039 |
| Level-2 Alarm: Charging Current Too High | ID000040 |
| Level-2 Alarm: Discharging Current Too High | ID000041 |
| Level-2 Alarm: Internal Communication Fault | ID000042 |
| Level-2 Alarm: Cell Voltage Fault | ID000043 |
| Level-2 Alarm: Cell Temperature Fault | ID000044 |
| Level-2 Alarm: High Voltage Abnormality | ID000045 |
| Level-2 Alarm: Terminal Pole overtemperature | ID000046 |
| Level-2 Alarm: Access Control Alarm | ID000047 |
| Level-1 Alarm: B+ Terminal Pole Temperature Fault | ID000048 |
| Level-1 Alarm: B- Terminal Pole Temperature Fault | ID000049 |
| Level-1 Alarm: Cell voltage too high | ID000050 |
| Level-1 Alarm: Cell Total voltage too low | ID000051 |
| Level-1 Alarm: Total voltage too high | ID000052 |
| Level-1 Alarm: Total voltage too low | ID000053 |
| Level-1 Alarm: Battery Discharging overtemperature | ID000054 |
| Level-1 Alarm: Battery Discharging undertemperature | ID000055 |
| Level-1 Alarm: Battery Charging overtemperature | ID000056 |
| Level-1 Alarm: Battery Charging undertemperature | ID000057 |
| Level-1 Alarm: Cell Temperature Difference Too Large | ID000058 |
| Level-1 Alarm: Charging Current Too High | ID000059 |
| Level-1 Alarm: Discharging Current Too High | ID000060 |
| Level-1 Alarm: Pre-charging Fault | ID000061 |
| Level-1 Alarm: Terminal Pole overtemperature | ID000062 |
| Level-1 Alarm: Ambient Temperature Fault | ID000063 |
| Level-1 Alarm: Ambient overtemperature | ID000064 |
| Level-1 Alarm: Ambient undertemperature | ID000065 |
| Air Conditioning Communication Status - Cluster 1 AC Data | ID000066 |
| Air Conditioner Fault Status | ID000067 |
| Access Control Status | ID000068 |
| Battery-Inverter Communication Status - Cluster 1 | ID000069 |
| Level-4 Alarm: Cell voltage too high - Cluster 2 | ID000070 |

| | |
|--|----------|
| Level-4 Alarm: Cell Total voltage too low | ID000071 |
| Level-4 Alarm: Pack voltage too high | ID000072 |
| Level-4 Alarm: Pack Total voltage too low | ID000073 |
| Level-4 Alarm: Battery Discharge overtemperature | ID000074 |
| Level-4 Alarm: Battery Charge overtemperature | ID000075 |
| Level-4 Alarm: Main Positive Relay Fault | ID000076 |
| Level-4 Alarm: Main Negative Relay Fault | ID000077 |
| Level-4 Alarm: Fire Protection Fault | ID000078 |
| Level-4 Alarm: Water Immersion Fault | ID000079 |
| Level-3 Alarm: Cell voltage too high | ID000080 |
| Level-3 Alarm: Cell Total voltage too low | ID000081 |
| Level-3 Alarm: Excessive Cell Voltage Difference (Level-1) | ID000082 |
| Level-3 Alarm: Pack voltage too high | ID000083 |
| Level-3 Alarm: Pack Total voltage too low | ID000084 |
| Level-3 Alarm: Battery Discharge overtemperature | ID000085 |
| Level-3 Alarm: Battery Discharge undertemperature | ID000086 |
| Level-3 Alarm: Battery Charge overtemperature | ID000087 |
| Level-3 Alarm: Battery Charge undertemperature | ID000088 |
| Level-3 Alarm: Charging Current Too High | ID000089 |
| Level-3 Alarm: Discharging Current Too High | ID000090 |
| Level-3 Alarm: Insulation Fault | ID000091 |
| Level-3 Alarm: Pre-charge Fault | ID000092 |
| Level-3 Alarm: AFE Chip Fault | ID000093 |
| Level-3 Alarm: Balancing Circuit Fault | ID000094 |
| Level-3 Alarm: Current Sensor Fault | ID000095 |
| Level-3 Alarm: Busbar overtemperature | ID000096 |
| Level-2 Alarm: Cell voltage too high | ID000097 |
| Level-2 Alarm: Cell Total voltage too low | ID000098 |
| Level-2 Alarm: Pack voltage too high | ID000099 |
| Level-2 Alarm: Pack Total voltage too low | ID000100 |
| Level-2 Alarm: Battery Discharge overtemperature | ID000101 |
| Level-2 Alarm: Battery Discharge undertemperature | ID000102 |
| Level-2 Alarm: Battery Charge overtemperature | ID000103 |
| Level-2 Alarm: Battery Charge undertemperature | ID000104 |
| Level-2 Alarm: Charging Current Too High | ID000105 |
| Level-2 Alarm: Discharging Current Too High | ID000106 |
| Level-2 Alarm: Internal Communication Fault | ID000107 |
| Level-2 Alarm: Cell Voltage Fault | ID000108 |
| Level-2 Alarm: Cell Temperature Fault | ID000109 |
| Level-2 Alarm: High Voltage Abnormality | ID000110 |
| Level-2 Alarm: Busbar overtemperature | ID000111 |
| Level-2 Alarm: Access Control Alarm | ID000112 |
| Level-1 Alarm: B+ Busbar Temperature Fault | ID000113 |

| | |
|--|----------|
| Level-1 Alarm: B- Busbar Temperature Fault | ID000114 |
| Level-1 Alarm: Cell voltage too high | ID000115 |
| Level-1 Alarm: Cell Total voltage too low | ID000116 |
| Level-1 Alarm: Pack voltage too high | ID000117 |
| Level-1 Alarm: Pack Total voltage too low | ID000118 |
| Level-1 Alarm: Battery Discharge overtemperature | ID000119 |
| Level-1 Alarm: Battery Discharge undertemperature | ID000120 |
| Level-1 Alarm: Battery Charge overtemperature | ID000121 |
| Level-1 Alarm: Battery Charge undertemperature | ID000122 |
| Level-1 Alarm: Excessive Cell Temperature Difference | ID000123 |
| Level-1 Alarm: Charging Current Too High | ID000124 |
| Level-1 Alarm: Discharging Current Too High | ID000125 |
| Level-1 Alarm: Pre-charge Fault | ID000126 |
| Level-1 Alarm: Busbar overtemperature | ID000127 |
| Level-1 Alarm: Ambient Temperature Fault | ID000128 |
| Level-1 Alarm: Ambient overtemperature | ID000129 |
| Level-1 Alarm: Ambient undertemperature | ID000130 |
| Air Conditioner Communication Status-Cluster 2 AC Data | ID000131 |
| Air Conditioner Fault Status | ID000132 |
| Access Control Status | ID000133 |
| Battery-Inverter Communication Status- Cluster 2 | ID000134 |
| Level-4 Alarm – Cell voltage too high - Cluster 3 | ID000135 |
| Level-4 Alarm – Cell Total voltage too low | ID000136 |
| Level-4 Alarm – Total voltage too high | ID000137 |
| Level-4 Alarm – Total voltage too low | ID000138 |
| Level-4 Alarm – Battery Discharge overtemperature | ID000139 |
| Level-4 Alarm – Battery Charge overtemperature | ID000140 |
| Level-4 Alarm – Main Positive Relay Fault | ID000141 |
| Level-4 Alarm – Main Negative Relay Fault | ID000142 |
| Level-4 Alarm – Fire Protection Fault | ID000143 |
| Level-4 Alarm –Water Immersion Fault | ID000144 |
| Level-3 Alarm – Cell voltage too high | ID000145 |
| Level-3 Alarm – Cell Total voltage too low | ID000146 |
| Level-3 Alarm – Excessive Cell Voltage Difference (Level-1) | ID000147 |
| Level-3 Alarm – Total voltage too high | ID000148 |
| Level-3 Alarm – Total voltage too low | ID000149 |
| Level-3 Alarm – Battery Discharge overtemperature | ID000150 |
| Level-3 Alarm – Battery Discharge undertemperature | ID000151 |
| Level-3 Alarm – Battery Charge overtemperature | ID000152 |
| Level-3 Alarm – Battery Charge undertemperature | ID000153 |
| Level-3 Alarm – Charging Current Too High | ID000154 |
| Level-3 Alarm – Discharging Current Too High | ID000155 |

| | |
|---|----------|
| Level-3 Alarm – Insulation Fault | ID000156 |
| Level-3 Alarm – Pre-Charge Fault | ID000157 |
| Level-3 Alarm – AFE Chip Fault | ID000158 |
| Level-3 Alarm – Balancing Circuit Fault | ID000159 |
| Level-3 Alarm – Current Sensor Fault | ID000160 |
| Level-3 Alarm – Terminal overtemperature | ID000161 |
| Level-2 Alarm – Cell voltage too high | ID000162 |
| Level-2 Alarm – Cell Total voltage too low | ID000163 |
| Level-2 Alarm – Total voltage too high | ID000164 |
| Level-2 Alarm – Total voltage too low | ID000165 |
| Level-2 Alarm – Battery Discharge overtemperature | ID000166 |
| Level-2 Alarm – Battery Discharge undertemperature | ID000167 |
| Level-2 Alarm – Battery Charge overtemperature | ID000168 |
| Level-2 Alarm – Battery Charge undertemperature | ID000169 |
| Level-2 Alarm – Charging Current Too High | ID000170 |
| Level-2 Alarm – Discharging Current Too High | ID000171 |
| Level-2 Alarm – Internal Communication Fault | ID000172 |
| Level-2 Alarm – Cell Voltage Fault | ID000173 |
| Level-2 Alarm – Cell Temperature Fault | ID000174 |
| Level-2 Alarm – Abnormal High Voltage Fault | ID000175 |
| Level-2 Alarm – Terminal overtemperature | ID000176 |
| Level-2 Alarm – Access Control Warning | ID000177 |
| Level-1 Alarm – B+ Terminal Temperature Fault | ID000178 |
| Level-1 Alarm – B- Terminal Temperature Fault | ID000179 |
| Level-1 Alarm – Cell voltage too high | ID000180 |
| Level-1 Alarm – Cell Total voltage too low | ID000181 |
| Level-1 Alarm – Total voltage too high | ID000182 |
| Level-1 Alarm – Total voltage too low | ID000183 |
| Level-1 Alarm – Battery Discharge overtemperature | ID000184 |
| Level-1 Alarm – Battery Discharge undertemperature | ID000185 |
| Level-1 Alarm – Battery Charge overtemperature | ID000186 |
| Level-1 Alarm – Battery Charge undertemperature | ID000187 |
| Level-1 Alarm – Excessive Temperature Difference Between Cells | ID000188 |
| Level-1 Alarm – Charging Current Too High | ID000189 |
| Level-1 Alarm – Discharging Current Too High | ID000190 |
| Level-1 Alarm – Pre-Charge Fault | ID000191 |
| Level-1 Alarm – Terminal overtemperature | ID000192 |
| Level-1 Alarm – Ambient Temperature Fault | ID000193 |
| Level-1 Alarm – Ambient overtemperature | ID000194 |
| Level-1 Alarm – Ambient undertemperature | ID000195 |
| Air Conditioner Communication Status- Cluster 3 AC Data | ID000196 |
| Air Conditioner Fault Status | ID000197 |

| | |
|--|----------|
| Access Control Status | ID000198 |
| Battery-Inverter Communication Status - Cluster 3 | ID000199 |
| Level-4 Alarm: Cell voltage too high - Cluster 4 | ID000200 |
| Level-4 Alarm: Cell Total voltage too low | ID000201 |
| Level-4 Alarm: Pack voltage too high | ID000202 |
| Level-4 Alarm: Pack Total voltage too low | ID000203 |
| Level-4 Alarm: Battery Discharge Overtemperature | ID000204 |
| Level-4 Alarm: Battery Charge Overtemperature | ID000205 |
| Level-4 Alarm: Main Positive Relay Fault | ID000206 |
| Level-4 Alarm: Main Negative Relay Fault | ID000207 |
| Level-4 Alarm: Fire Protection Fault | ID000208 |
| Level-4 Alarm: Water Immersion Fault | ID000209 |
| Level-3 Alarm: Cell voltage too high | ID000210 |
| Level-3 Alarm: Cell Total voltage too low | ID000211 |
| Level-3 Alarm: Excessive Cell Voltage Difference (Level-1) | ID000212 |
| Level-3 Alarm: Pack voltage too high | ID000213 |
| Level-3 Alarm: Pack Total voltage too low | ID000214 |
| Level-3 Alarm: Battery Discharge Overtemperature | ID000215 |
| Level-3 Alarm: Battery Discharge Undertemperature | ID000216 |
| Level-3 Alarm: Battery Charge Overtemperature | ID000217 |
| Level-3 Alarm: Battery Charge Undertemperature | ID000218 |
| Level-3 Alarm: Charge Overcurrent | ID000219 |
| Level-3 Alarm: Discharge Overcurrent | ID000220 |
| Level-3 Alarm: Insulation Fault | ID000221 |
| Level-3 Alarm: Pre-Charge Fault | ID000222 |
| Level-3 Alarm: AFE Chip Fault | ID000223 |
| Level-3 Alarm: Balancing Circuit Fault | ID000224 |
| Level-3 Alarm: Current Sensor Fault | ID000225 |
| Level-3 Alarm: Terminal overtemperature | ID000226 |
| Level-2 Alarm: Cell voltage too high | ID000227 |
| Level-2 Alarm: Cell Total voltage too low | ID000228 |
| Level-2 Alarm: Pack voltage too high | ID000229 |
| Level-2 Alarm: Pack Total voltage too low | ID000230 |
| Level-2 Alarm: Battery Discharge Overtemperature | ID000231 |
| Level-2 Alarm: Battery Discharge Undertemperature | ID000232 |
| Level-2 Alarm: Battery Charge Overtemperature | ID000233 |
| Level-2 Alarm: Battery Charge Undertemperature | ID000234 |
| Level-2 Alarm: Charge Overcurrent | ID000235 |
| Level-2 Alarm: Discharge Overcurrent | ID000236 |
| Level-2 Alarm: Internal Communication Fault | ID000237 |
| Level-2 Alarm: Cell Voltage Fault | ID000238 |
| Level-2 Alarm: Cell Temperature Fault | ID000239 |
| Level-2 Alarm: High Voltage Abnormality | ID000240 |

| | |
|---|----------|
| Level-2 Alarm: Terminal overtemperature | ID000241 |
| Level-2 Alarm: Access Control Alarm | ID000242 |
| Level-1 Alarm: B+ Terminal Temperature Fault | ID000243 |
| Level-1 Alarm: B- Terminal Temperature Fault | ID000244 |
| Level-1 Alarm: Cell voltage too high | ID000245 |
| Level-1 Alarm: Cell Total voltage too low | ID000246 |
| Level-1 Alarm: Pack voltage too high | ID000247 |
| Level-1 Alarm: Pack Total voltage too low | ID000248 |
| Level-1 Alarm: Battery Discharge Overtemperature | ID000249 |
| Level-1 Alarm: Battery Discharge Undertemperature | ID000250 |
| Level-1 Alarm: Battery Charge Overtemperature | ID000251 |
| Level-1 Alarm: Battery Charge Undertemperature | ID000252 |
| Level-1 Alarm: Excessive Cell Temperature Difference | ID000253 |
| Level-1 Alarm: Charge Overcurrent | ID000254 |
| Level-1 Alarm: Discharge Overcurrent | ID000255 |
| Level-1 Alarm: Pre-Charge Fault | ID000256 |
| Level-1 Alarm: Terminal overtemperature | ID000257 |
| Level-1 Alarm: Ambient Temperature Fault | ID000258 |
| Level-1 Alarm: Ambient overtemperature | ID000259 |
| Level-1 Alarm: Ambient undertemperature | ID000260 |
| Air Conditioner Communication Status- Cluster 4 AC Data | ID000261 |
| Air Conditioner Fault Status | ID000262 |
| Access Control Status | ID000263 |
| Battery-Inverter Communication Status - Cluster 4 | ID000264 |
| | |
| | |
| Empty EPO Status | ID000265 |
| Level-1 Alarm: Excessive Voltage Difference Between Racks in Branch | ID000266 |
| Level-1 Alarm: Communication Interruption Between Master and Slave MBMU | ID000267 |
| Level-2 Fault: MBMU Charge/Discharge Overcurrent | ID000268 |
| | |
| | |
| Excessive Total Voltage Differential | ID000300 |
| Surge Protector Fault | ID000301 |
| Total Voltage Sampling Fault | ID000302 |
| SBMU to BMU Communication Fault | ID000303 |
| SBMU to MBMU Communication Fault | ID000304 |
| BMU Auto Addressing Failure | ID000305 |
| AFE Communication Fault | ID000306 |
| Battery System Fault | ID000307 |
| | |

| | |
|--------------------------------------|----------|
| | |
| Excessive Total Voltage Differential | ID000320 |
| Surge Protector Fault | ID000321 |
| Total Voltage Sampling Fault | ID000322 |
| SBMU to BMU Communication Fault | ID000323 |
| SBMU to MBMU Communication Fault | ID000324 |
| BMU Auto Addressing Failure | ID000325 |
| AFE Communication Fault | ID000326 |
| Battery System Fault | ID000327 |
| | |
| | |
| Excessive Total Voltage Differential | ID000340 |
| Surge Protector Fault | ID000341 |
| Total Voltage Sampling Fault | ID000342 |
| SBMU to BMU Communication Fault | ID000343 |
| SBMU to MBMU Communication Fault | ID000344 |
| BMU Auto Addressing Failure | ID000345 |
| AFE Communication Fault | ID000346 |
| Battery System Fault | ID000347 |
| | |
| | |
| Excessive Total Voltage Differential | ID000360 |
| Surge Protector Fault | ID000361 |
| Total Voltage Sampling Fault | ID000362 |
| SBMU to BMU Communication Fault | ID000363 |
| SBMU to MBMU Communication Fault | ID000364 |
| BMU Auto Addressing Failure | ID000365 |
| AFE Communication Fault | ID000366 |
| Battery System Fault | ID000367 |

5.2 Fire Protection Unit

Press the fire activation box test button, and check for the illumination of both the power indicator light and circuit monitoring indicator light, If the power indicator light does not illuminate, replace the starter fire activation box.

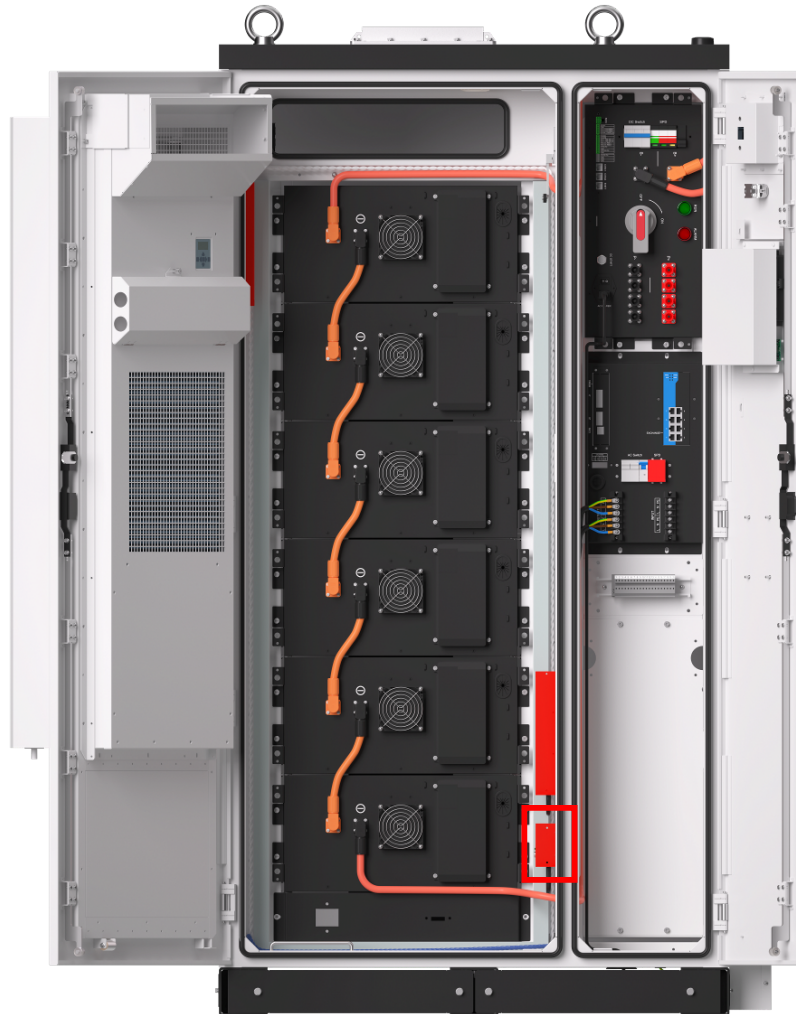

73 → Fire Alarm Activation Indicator Light
← Test Button

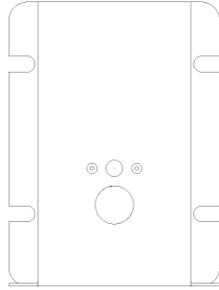

Location of Fire Alarm Activation Box

6 Cabinet EMS Basic Setting

6.1 Time and Time Zone Setting (if Applicable)

NOTICE

- If it's connected in internet, the time can syn from the internet.
- Go to “Setting”-“Run Mode”-“Screen”.

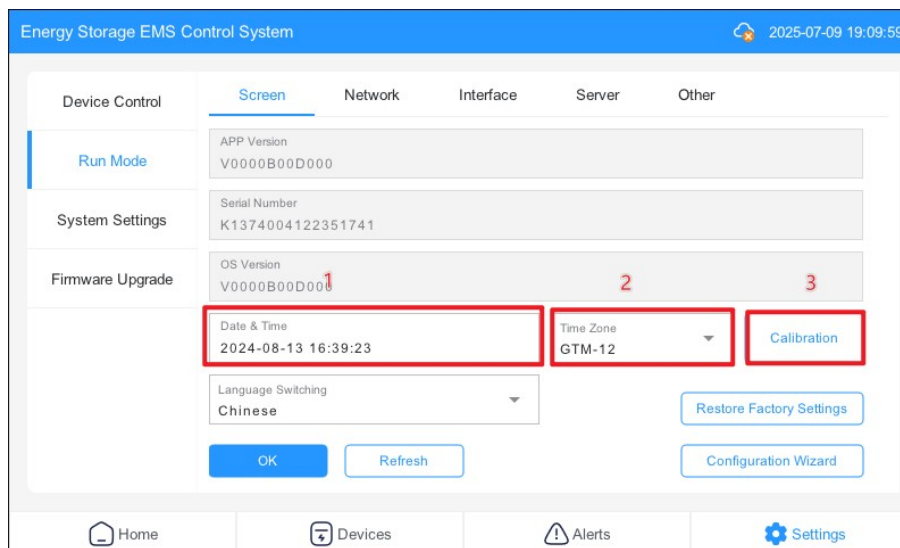

6.2 Grid Code Setting

NOTICE

- Go to “Setting”-“Run Mode”-“Other”-“Grid Standard”.

Energy Storage EMS Control System 2025-12-30 11:14:47

Device Control Screen Network Interface Server **3 Other**

Running Mode Local Modbus RTU Address: 1 Interface Protocol Type: Kstar

2 System Settings Grid Standard: **Australia A** **4** Interface Protocol Port: 2000

Firmware Upgrade DI-power control: Disable Power Control Mode: Three-Phase Hybrid

OK Refresh Meter Settings

Home Devices Alerts (3) **1 Settings**

Energy Storage EMS Control System 2025-12-30 11:14:47

Device Control Screen Network Interface Server Other

Running Mode Local Modbus RTU Address: 1 Interface Protocol Type: Kstar

System Settings Grid Standard: Aus Please Input a Password

Firmware Upgrade DI-power control: Dis Please enter... Hybrid

OK Refresh Meter Settings

Home Devices Alerts (3) Settings

Energy Storage EMS Control System 2025-12-30 11:27:24

Device Control Screen Network Interface Server Other

Running Mode Local Modbus RTU Address: 1 Interface Protocol Type: Kstar

System Settings Grid Standard: Australia A

Firmware Upgrade Australia A ✓ Ausgrid Australia B Australia C Endeavour

OK Refresh Meter Settings

Home Devices Alerts (3) Settings

NOTICE

- If you need to change the grid standard settings, you need to enter a password to select the grid standard type.

6.3 Check software firmware version

The screenshot displays the 'Energy Storage EMS Control System' interface. The top navigation bar includes the system name and the date/time '2025-12-29 19:07:43'. The main content area is divided into sections: 'Device Control', 'Running Mode', and 'System Settings'. The 'System Settings' section is expanded, showing the 'Firmware Upgrade' option. A table lists the firmware versions for various components: HMI (V010B000D030), BMS 1 (V000B000D000), PCS 1 (Version 1) (V000B000D000), PCS 1 (Version 2) (V000B000D000), and PCS 1 (ARM Version) (V000B000D000). Below the table, there is a 'Device Type' dropdown menu set to 'HMI', a 'Firmware File' input field with a 'Browse' button, and a 'Start Upgrade' button. The bottom navigation bar contains icons for 'Home', 'Devices', 'Alerts (3)', and 'Settings'.

| | |
|---------------------|--------------|
| HMI | V010B000D030 |
| BMS 1 | V000B000D000 |
| PCS 1 (Version 1) | V000B000D000 |
| PCS 1 (Version 2) | V000B000D000 |
| PCS 1 (ARM Version) | V000B000D000 |

6.4 Over/under voltage and frequency Setting

NOTICE

- Go to "Setting"->"Device Control"->"PCS"->"More Settings"

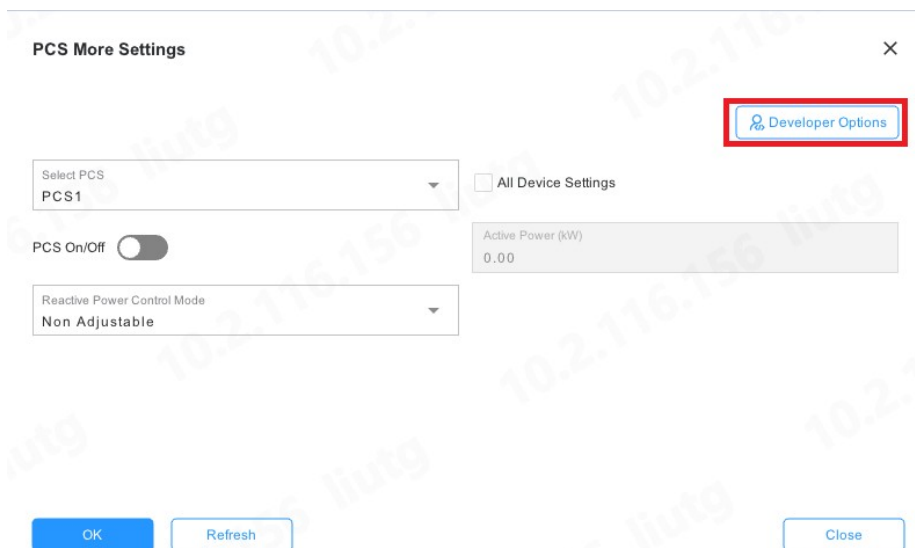
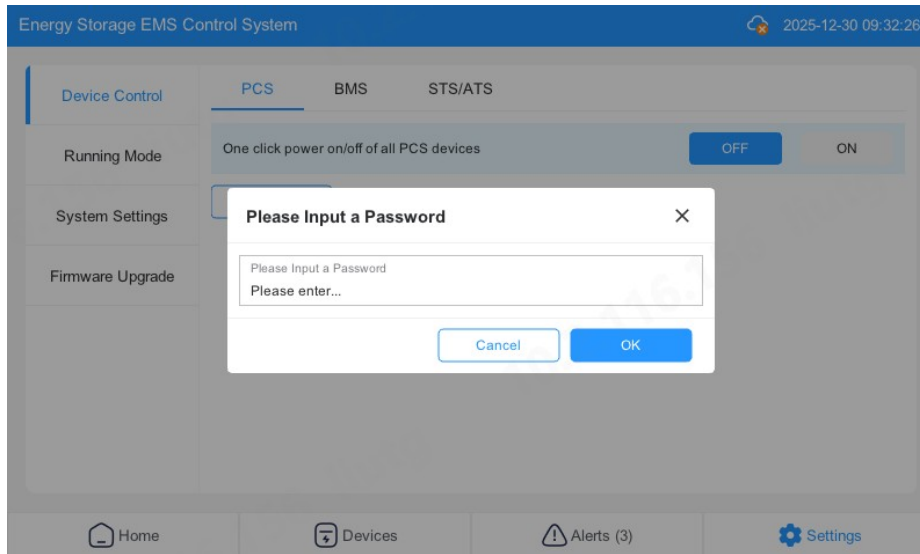
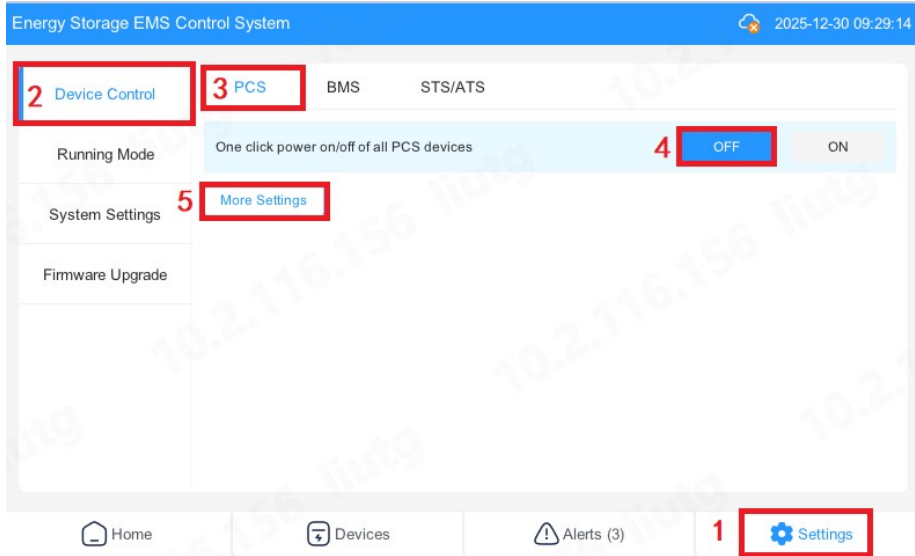

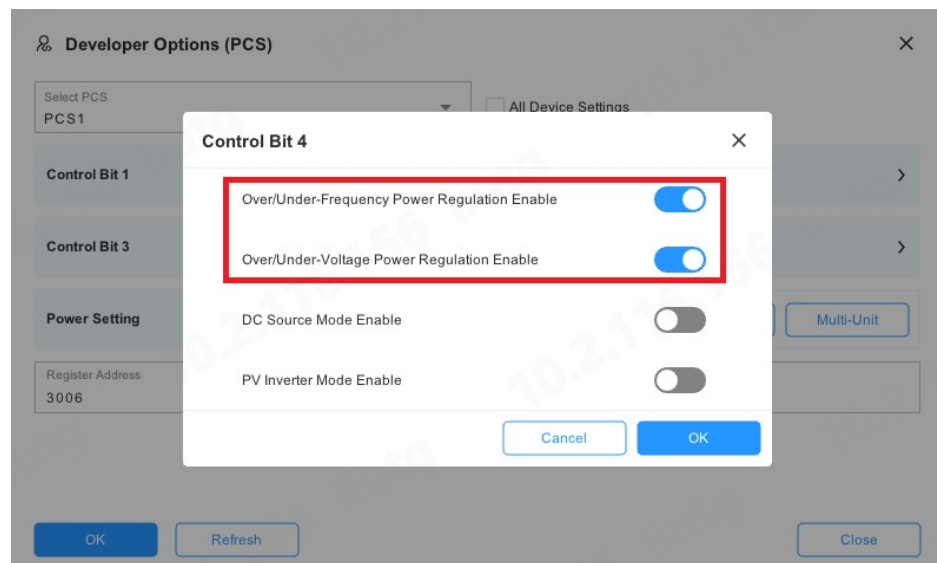
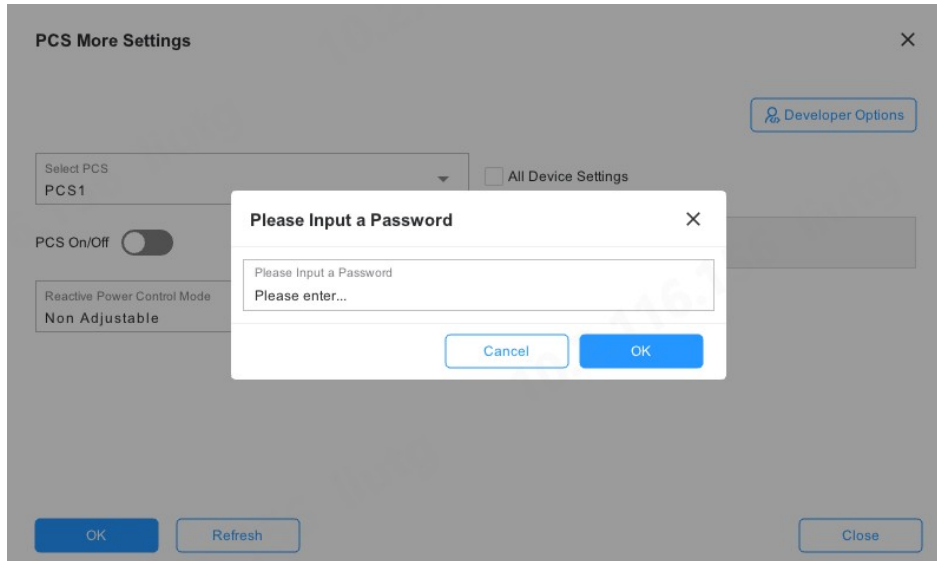

NOTICE

- The operating authority password in the Australian user manual cannot be explained in the installation manual.

6.5 Reverse Power Protection/Demand control settings

The screenshot displays the 'Energy Storage EMS Control System' interface. At the top, the title bar shows the system name and the date/time '2025-12-30 13:41:18'. The main content area is divided into sections: 'Device Control' with 'Remote Control' set to 'Disable' and 'Running Mode' set to 'Manual Control'; 'System Settings' with 'Reverse Power Protection Control' checked and 'Value (kW)' set to '0.00'; and 'Firmware Upgrade' with 'Demand Control' checked and 'Value (kW)' set to '100.00'. A red box highlights the 'Running Mode' dropdown menu. Another red box highlights the 'Reverse Power Protection Control' checkbox and its value field. A third red box highlights the 'Demand Control' checkbox and its value field. At the bottom, there are 'OK' and 'Refresh' buttons. The bottom navigation bar includes 'Home', 'Devices', 'Alerts (3)', and 'Settings' (highlighted with a red box and labeled '1').

This interface can view reverse power protection and demand control. If you need reverse power protection and demand control, you need to enter a password. The check in the picture means to enable the corresponding settings. The right side is to set the corresponding power. Please connect the power grid meter. For the power grid meter wiring, please refer to the meter wiring section.

The screenshot shows the same 'Energy Storage EMS Control System' interface as above, but with a 'Please Input a Password' dialog box overlaid. The dialog box has a title bar with a close button (X), a text input field, and 'Cancel' and 'OK' buttons. The background settings are partially visible, with 'Reverse Power Protection Control' and 'Demand Control' checked. The 'Settings' button in the bottom navigation bar is highlighted with a red box.

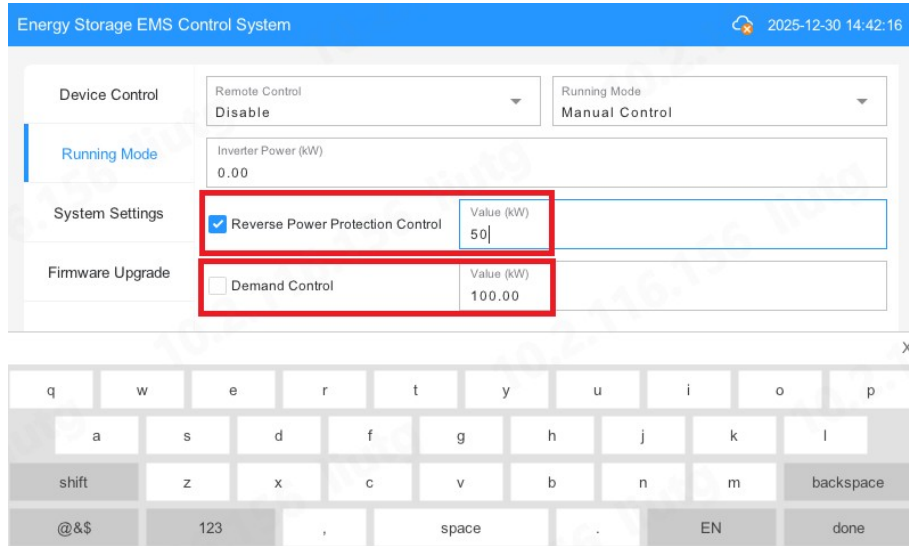

6.6 PCS total power settings

NOTICE

- Go to “Setting”-“Device Control”-“PCS”-“More Settings”

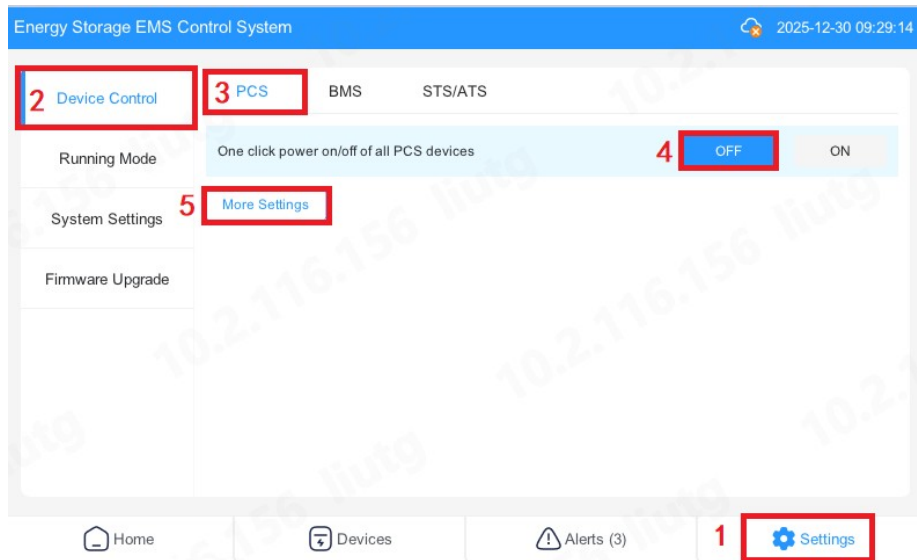

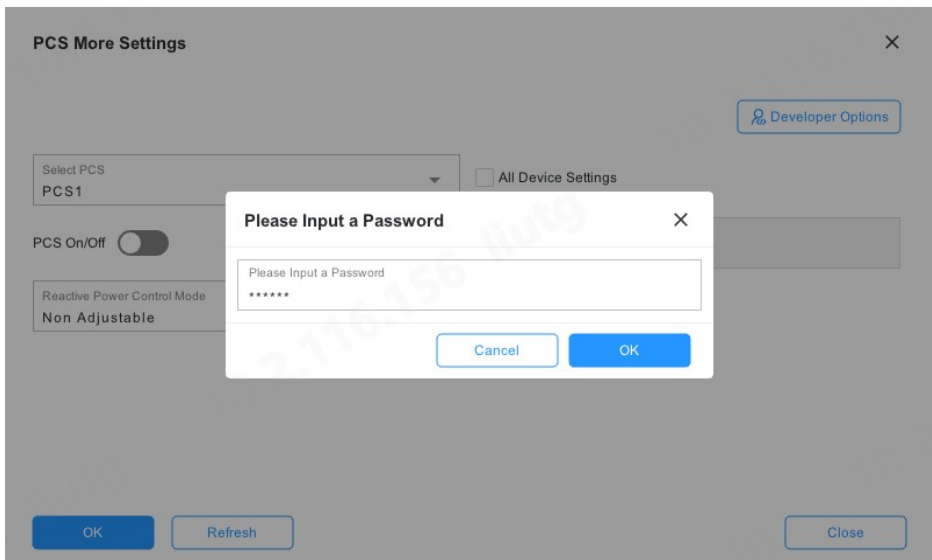
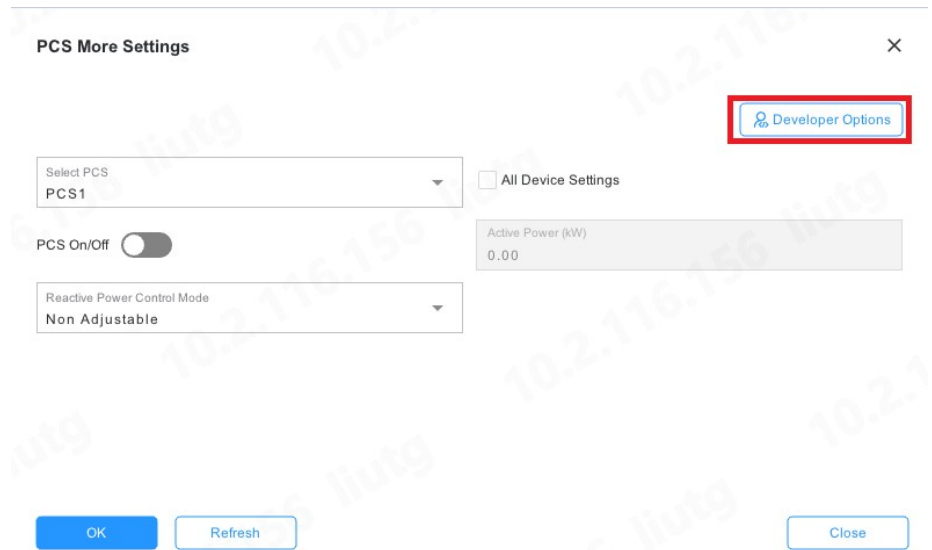
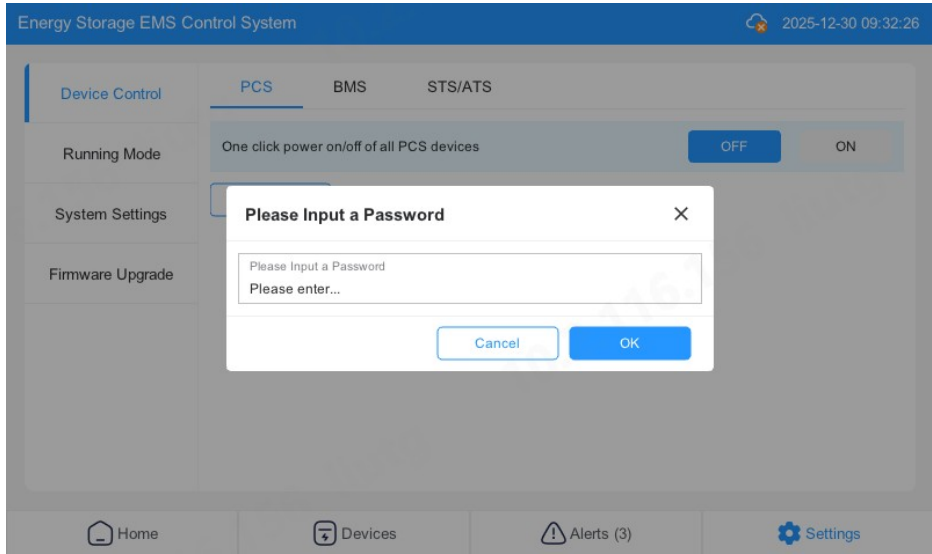

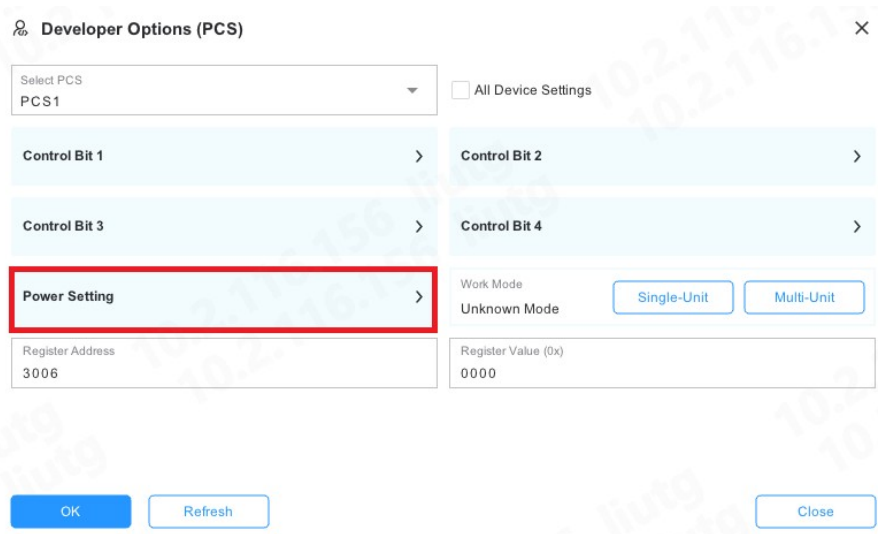

NOTICE

- Click “Power Setting” to set the maximum usable power of a single PCS.

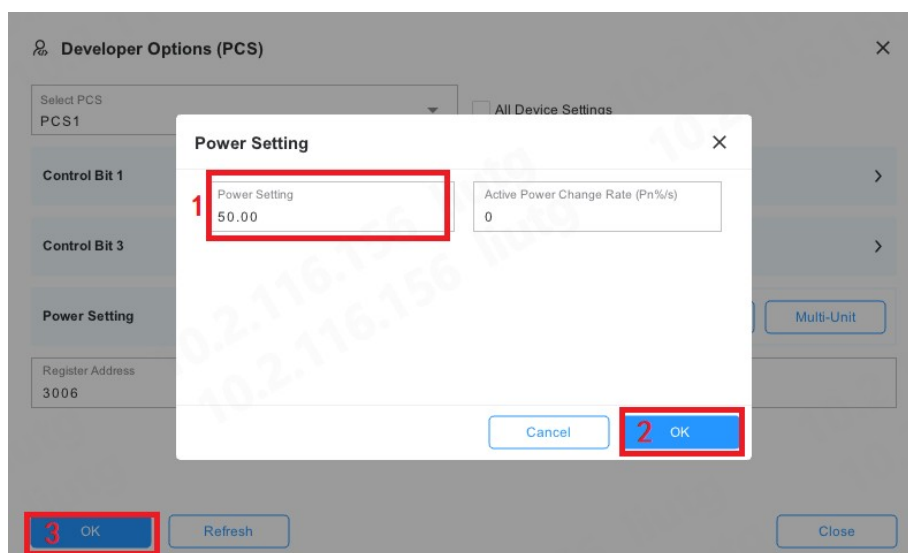

6.7 Operation Mode Setting

NOTICE

- If the ESS unit systems are connected on the EMS01D.
- Enable the remote control and set the run mode as “manual control”.
- The set the control mode on the EMS01D.

Set the system as “manual control”, “self consumption”, “peak shaving” and “TOU” accordingly.

Energy Storage EMS Control System 2025-07-10 21:47:52

Device Control Remote Control **1** Disable Run Mode **2** Manual Control

Run Mode Converter Power (kW) **3** 60

System Settings Anti Backflow Control Value (kW) 60

Firmware Upgrade Demand Control Value (kW) **4** 60

OK Refresh

Home Devices Alerts Settings

Energy Storage EMS Control System 2025-07-10 21:57:10

Device Control Remote Control **1** Disable Run Mode **2** Self Consumption

Run Mode Charging Time **3** Start Time 00:00 End Time 00:00 Power (kW) 60

System Settings Start Time 00:00 End Time 00:00 Power (kW) 60

Firmware Upgrade Discharging Time **4** Start Time 00:00 End Time 00:00 Power (kW) 60

Start Time 00:00 End Time 00:00 Power (kW) 60

Anti Backflow Control Value (kW) 60

OK Refresh

Home Devices Alerts Settings

Energy Storage EMS Control System 2025-07-10 22:04:03

Device Control Remote Control **1** Disable Run Mode **2** Time of Use

Run Mode Anti Backflow Control Value (kW) 60 **3**

System Settings Demand Control Value (kW) 60

Firmware Upgrade **4**

OK Refresh **5**

Home Devices Alerts Settings

⌚ Run Mode Time-Sharing Setting



Week **1**
Sunday

[Copy Settings](#)

| | Start Time | End Time | Power (kW) |
|---------------|------------|----------|------------|
| Time Period 1 | 00:00 | 00:00 | 60 |
| Time Period 2 | 00:00 | 00:00 | 60 |
| Time Period 3 | 00:00 | 00:00 | 60 |
| Time Period 4 | 00:00 | 00:00 | 60 |
| Time Period 5 | 00:00 | 00:00 | 60 |
| Time Period 6 | 00:00 | 00:00 | 60 |

[Close](#)

7 Cloud Platform Connection

The Energy Storage EMS is pre-installed on the EMS touch screen on the front door of the battery cabinet. During commissioning, no external network connection is required to access the local EMS screen. After the cabinet is powered on, the EMS touch screen communicates with the EMS controller through the internal Ethernet connection. For connection to a cloud platform or upper monitoring system, connect a standard Ethernet cable to the Ethernet lightning arrester/user interface shown in Section 3.6.

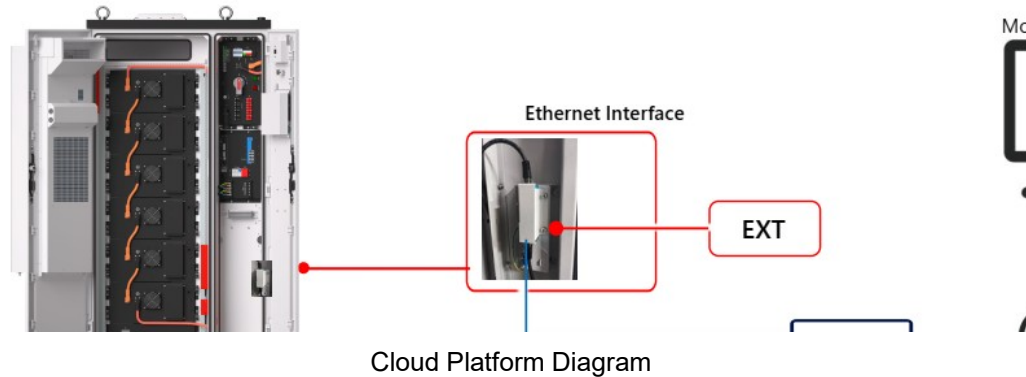

7.1 Network Wiring and Settings

Step1

“Setting”-“System Settings”-“Server”-“Sync”-“OK”

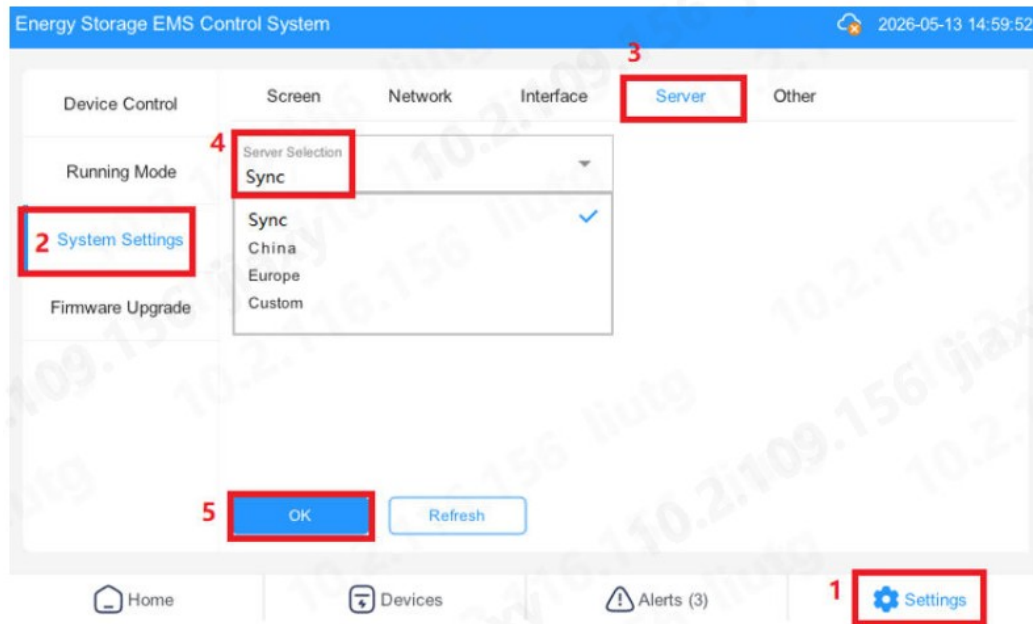

Step2

Note: If the S/N on the EMS screen is the same as the battery cabinet S/N, do not change it. The S/N must match the battery cabinet S/N and is case-sensitive:
 "Setting"->"System Settings"->"Screen", Click this to "Refresh" 10 times to set the SN number, click "OK" at the bottom to save set.

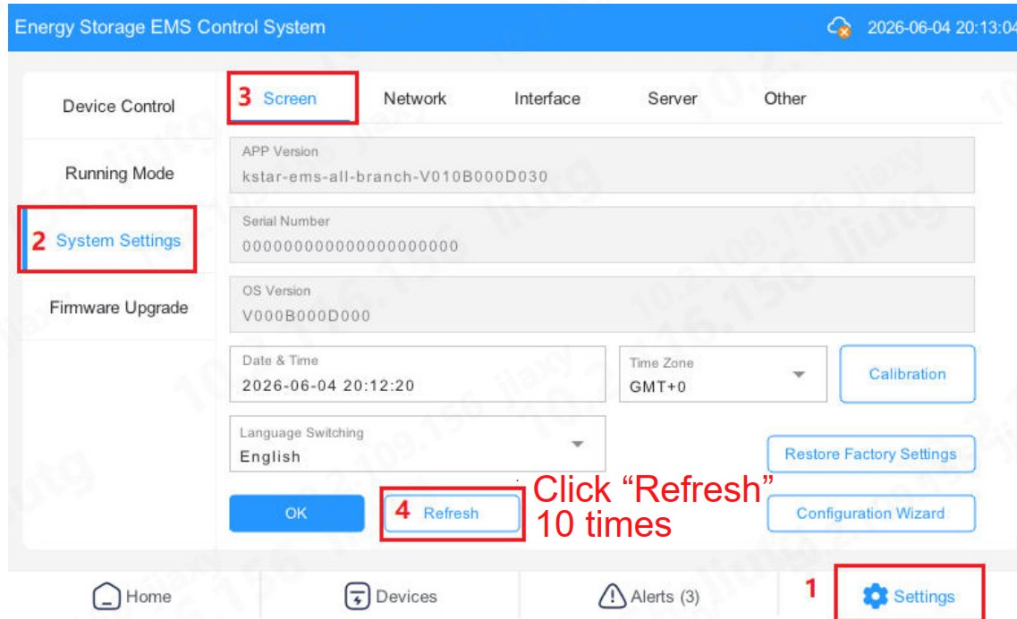

"Setting"->"System Settings"->"Screen", Set this SN number as the battery cabinet SN number, click "OK" at the bottom to save set.



Step3

Note: The device supports Ethernet, DHCP. Please inform the customer to open the following address for the IP port used by the company and allow the firewall to pass through.

- 51.141.112.234 2800 (encrypted)
- 51.141.112.234 2900 (unencrypted)
- 111.230.141.84 2800 (encrypted)

111.230.141.84 2900 (unencrypted)

20.82.106.247 19636 (encrypted)

20.82.106.247 9636 (unencrypted)

193.112.41.194 21

51.141.112.234 2700

159.75.9.163 2700

Unable to access the internet without using the collector.

Automatic DHCP Network Connection

“Setting”-“System Settings”-“Network”-“DHCP”-“OK”

The screenshot displays the 'Energy Storage EMS Control System' web interface. The top navigation bar is blue with the system name. Below it, a menu bar contains 'Device Control', 'Screen', '3 Network' (highlighted with a red box), 'Interface', 'Server', and 'Other'. The main content area is divided into sections: 'Running Mode' (with a dropdown menu set to 'Ethernet'), '2 System Settings' (highlighted with a red box), and 'Firmware Upgrade'. Under 'System Settings', the 'Ethernet 4' section is active, showing 'DHCP' selected with a radio button (highlighted with a red box) and 'Static IP' unselected. Below this, there are input fields for 'IP' (192.168.1.1), 'Subnet Mask' (255.255.255.0), 'Default Gateway' (192.168.1.1), and 'DNS 1' (192.168.1.1). At the bottom, there is a 'DNS 2' field and two buttons: '5 OK' (highlighted with a red box) and 'Refresh'.

Note: If the user network does not support DHCP automatic network connection, use the static IP address of the network port for network connection.

“Setting”-“System Settings”-“Network”-“Static IP”-“OK”

Enter the static IP address of the network port. After setting it, click "OK".

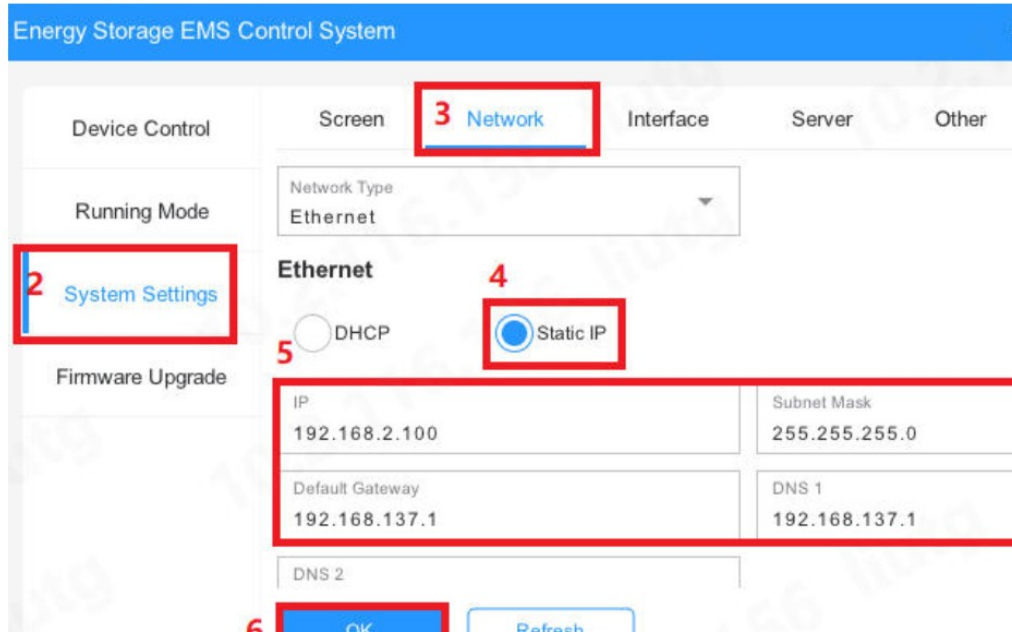

7.2 Connecting the Collector to the KSTAR Sync Platform

Step1

Register using the KSTAR Sync website or mobile app.

Log in to Sync, then add the plant and collector information.

KSTAR Sync web address: <https://sync.ksdatacloud.com/>

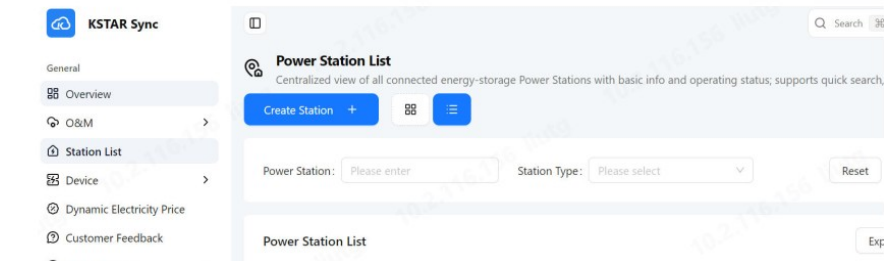
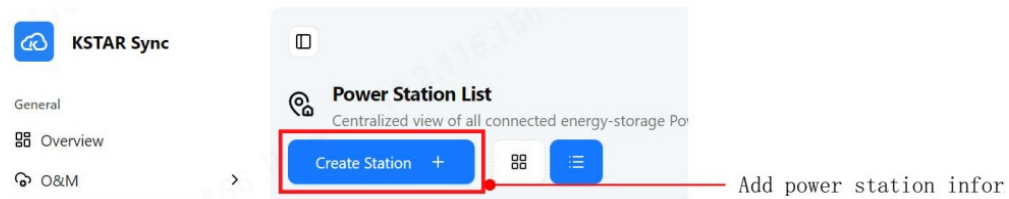

Step2

Register using the KSTAR Sync mobile app.

1. Android phone: Visit the Google Play Store, then search for and download KSTAR

Sync.

2. iOS phone: Visit the App Store, then search for and download KSTAR Sync.
3. Scan the QR code with a mobile phone to download KSTAR Sync.



Log in to Sync using the mobile app, then add the plant and collector information.

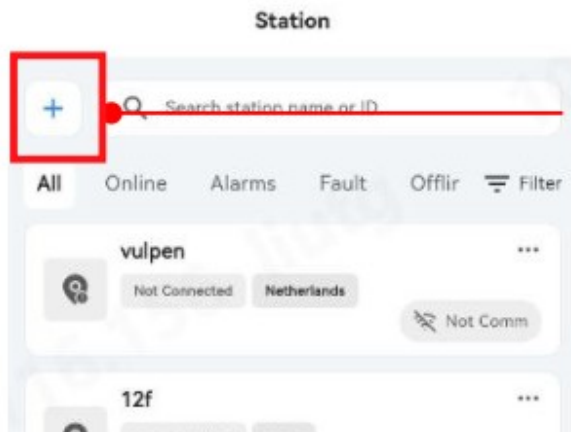



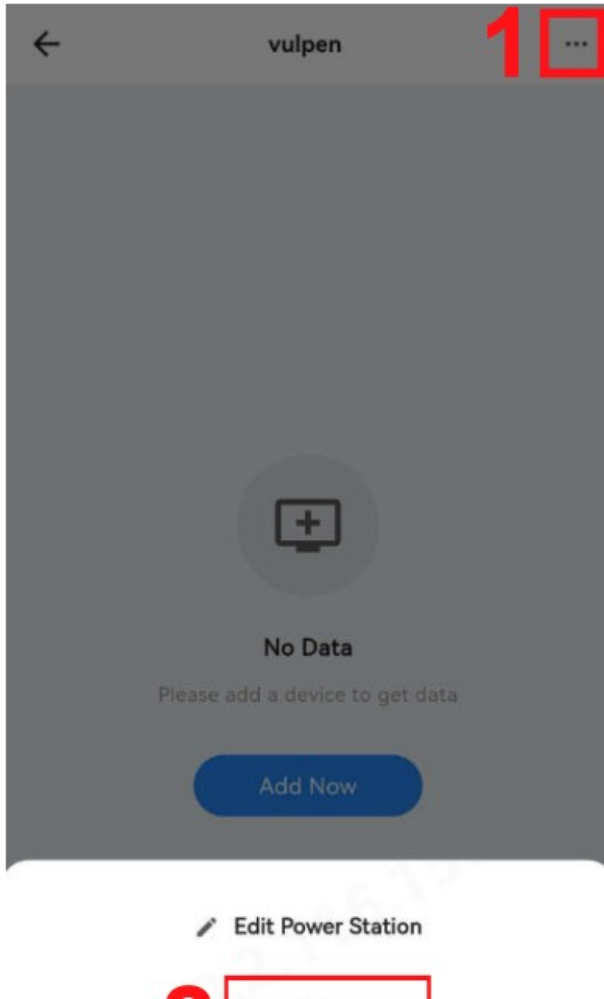



Add power station i
After adding the pc
station, click into
station and then ad
collector device fc
station.



8 List of accessories

A single battery cabinet contains the following accessories (placed in the accessory box):

| Storage cabinet system | User manual | Certificate of conformity | Warranty card |
|---|---|--|---|
|  |  |  |  |
| Key | Base baffle | Factory test report | Bellows |

| | | | |
|---|---|--|---|
|  |  |  |  |
| Fireproof mud | Desiccant | Ground wire | Trunking |
|  |  |  |  |
| Stylus | | | |
|  | | | |

■ BC107DE2/BC96DE2-AU Packing list

| Serial number | Name | Number | Unit | Purpose |
|---------------|-------------------------------|--------|------|--|
| Accessories 1 | Energy storage cabinet system | 1 | PCS | Standard configuration. |
| Accessories 2 | Fireproof mud | 2 | KG | Standard configuration(Fire mud 0.5kg (4pcs))screw M6*20 (8pcs)) |
| Accessories 3 | Base baffle | 4 | PCS | Battery cabinet base baffle |
| Accessories 4 | Desiccant | 1 | PCS | Moisture-proof |
| Accessories 5 | Ground wire | 0.7 | M | Connection of battery cabinet and ground wire copper bar |
| Accessories 6 | User Manual | 1 | PCS | User Manual |
| Accessories 7 | Wire trunking | 1 | PCS | Trunking for connection to PCS |
| Accessories 8 | Corrugated pipe | 1 | PCS | Bellows for PCS connection line(Corrugated pipe Φ29mm 5.5M and Corrugated pipe Φ17mm 10m, screw M4*10 (16pcs)) |
| Accessories 9 | Factory test report | 1 | PCS | Standard configuration |

| | | | | |
|----------------|---------------------------|---|-----|---|
| Accessories 10 | Certificate of conformity | 1 | PCS | Standard configuration |
| Accessories 11 | Warranty card | 1 | PCS | Standard configuration |
| Accessories 12 | Key | 1 | PCS | Standard configuration (includes EMS baffle and door key) |
| Accessories 13 | Touch screen pen | 1 | PCS | Standard configuration |

9 Terminology

(1) Cell

Single cell.

(2) Battery module

A combination of multiple cells connected in series, parallel, or series-parallel, with only one pair of positive and negative output terminals, used as a power source.

(3) Battery cluster

Multiple battery packs, a HVB, and connecting cables form a complete battery cluster, featuring independent external energy interaction and self-protection functions.

(4) Battery array

Multiple battery clusters form a battery array, and the energy interactions of the clusters are managed uniformly through a three-level architecture control mode.

(5) Battery management system (BMS)

An electronic device that controls or manages the electrical or thermal performance of a battery system.

- BMU (battery management unit)
- SBMU(slave battery management unit)
- MBMU (master battery management unit)
- EMS (energy management system)

(6) Battery system

The energy storage device integrates a battery module or battery pack, a battery management system, a high-voltage circuit, and a low-voltage circuit.

(7) Battery capacity

The size of the battery storage capacity.

(8) State of charge (SOC)

The percentage of the capacity of the battery cell, module, battery pack, or system that can be released according to the manufacturer's specified conditions, also known as the remaining capacity.

(9) State of health (SOH)

The ratio of the actual performance of the battery to the deviation from the normal design specifications.